

# AKUSENSE

## LITHIUM PROCESS

SENSOR APPLICATION  
SOLUTIONS



For more product details  
please scan the code

**Website**  
[www.akusense.cn](http://www.akusense.cn)

**Telephone**  
400-8856656

**Headquarters**  
Shenzhen

**Subsidiary**  
Changsha | Suzhou

**Overseas Resident Office**  
Germany | United States | Thailand

**China Resident Office**

Guangzhou | Dongguan | Chengdu | Wuhan | Fuzhou | Hefei | Nanjing | Beijing | Qingdao



# VISION

## VISION OF AKUSENSE

TO SUPPORT CUSTOMERS TO BE INDUSTRY LEADERS



## COMPANY OVERVIEW

Shenzhen Akusense Technology Co., Ltd. is an innovation company specialized in industrial photoelectric sensors and deep learning technology, majorly focusing on manufacturing high precision positioning, deep learning, precision measurement, and obstacle avoidance sensors and providing related solutions. We provide precision intelligence and AI sensing technology for such industries as 3C electronics, new energy, semiconductor manufacturing process, medical electronics and service robotics. There are two brands serving the market, AKUSENSE and MEIJIDENKI.

Our Production and Research Team accounts for more than 30% of the total. The core team brings together a group of senior scientists and engineers who have been engaged in industrial sensors for 20 years. We have our own labs for precision optics and AI vision. As more than 10% of our annual revenue are invested in research and development each year, our new products are launched very fast. We are an intelligent sensor company with more than 120 core patents as well as many international certificates such as ISO 9001, ISO 14000, CE, UL, TUV and ROHS. Meanwhile, OEM and ODM services are available. With over 6,000,000 sensors being exported to more than 70 countries and regions throughout the world per year, Akusense is helping our customers to become the industry leaders from Smart Industry and IOT Field in the era of Industry 4.0.

18000<sup>+</sup>  
Amount of users

200<sup>+</sup>  
Agent City Distribution

240<sup>+</sup>  
Partners

6million<sup>+</sup>/<sub>year</sub>  
Annual Sales

70<sup>+</sup>  
Country Distribution

120<sup>+</sup>  
Core patent

7  
7 of China's top 10 industries are AKUSENSE users

\* Above statistics are as of April 2023



# ADVANTAGE

Leading in independent technology and algorithms more than 20 years experience in the R&D team of industrial sensor experts.  
Rich and mature product line and system, achieving precision+intelligence+quality+innovation.  
Rich experience in application scenarios, 3C Industry+New Energy industry+Robot and AGV industry.  
Support solution customization, technology training, sample trial, industry excellent experience.

# QUALITY CONCEPT

DO IT RIGHT  
AT THE FIRST TIME

# INDUSTRIAL CUSTOMIZATION EXPERT



- Industrial sensors design  
(Position detection, measurement, safety identification and diagnosis)
- UL/CSA/CE standard requirements design
- Adaptive displacement sensor design
- High-precision analog sensors design
- Product development process management  
and manufacturability design

# SPECIALISING IN INTELLIGENT SENSING SOLUTIONS FOR LITHIUM-ION EQUIPMENT



## Customised to your needs

Pre-engineered solutions are individually tailored to the specific application of your equipment, saving time and costs and guaranteeing optimum performance.



## Complete service system

Our project team will co-operate with you from the collection of requirements to testing and validation, as well as after-sales service. The office network of 10+ cities (constantly expanding) ensures that we can respond quickly to the needs of users.



## Rich industry experience

Rich product lines and project experience, as well as the hardcore R&D team of senior engineers at home and abroad, support the engineers to customise high-quality and efficient solutions for you, so that your equipment is more competitive in the market.

## Your solution path

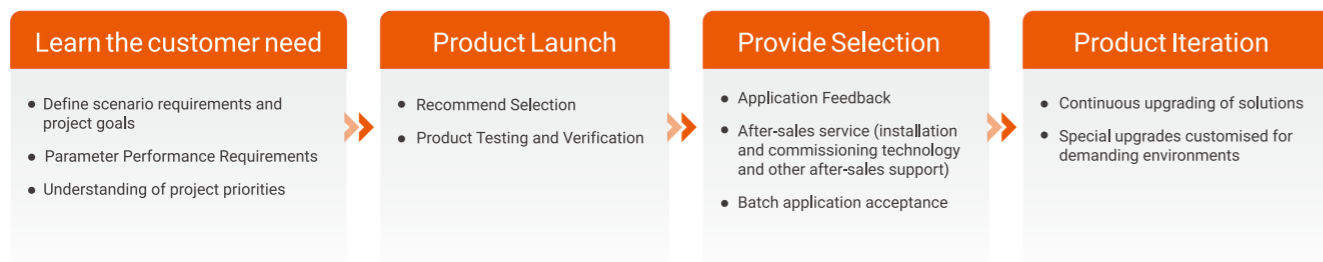

# DEVELOPMENT HISTORY

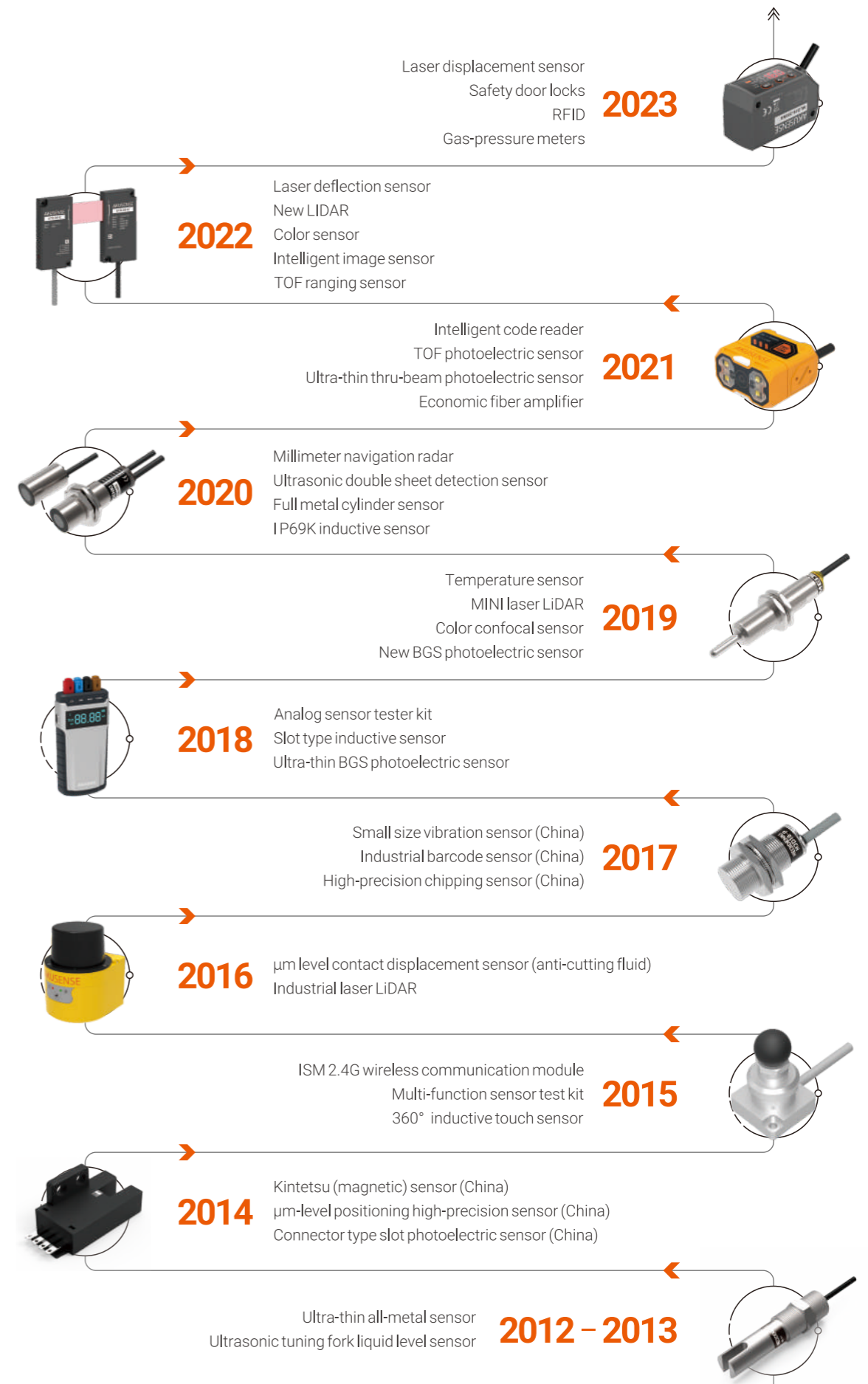



## CONTENT

### Sensor Selection on Lithium Devices

Lithium Coating Machine	P07
Lithium Winding Machine	P11
Lithium Laminating Machine	P15
Lithium Wrapping Machine	P19
Lithium Tab Cutting Machine	P23
Lithium Shelling Machine	P27
Lithium Laser Welding Machine	P31
Lithium Smart Storage	P35
Sensor Parameter	P39

01

Lithium Coating Machine

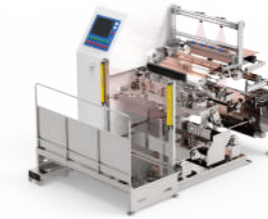

02

Lithium Winding Machine

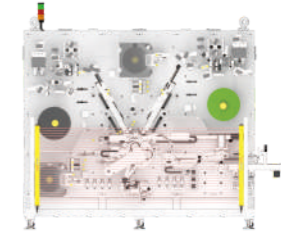

03

Lithium Laminating Machine

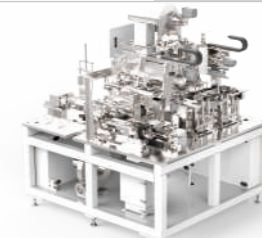

04

Lithium Wrapping Machine

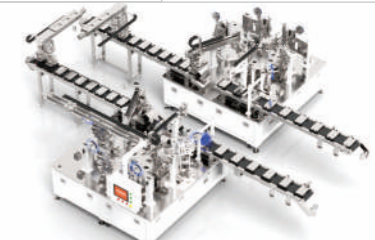

05

Lithium Tab Cutting Machine

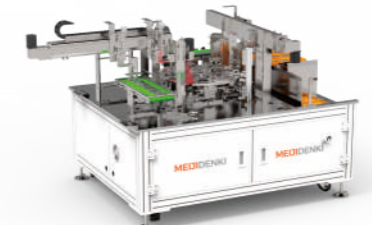

06

Lithium Shelling Machine

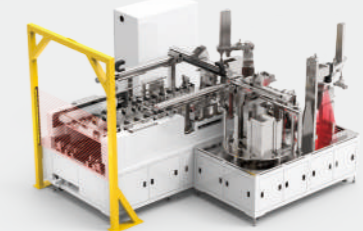

07

Lithium Laser Welding Machine

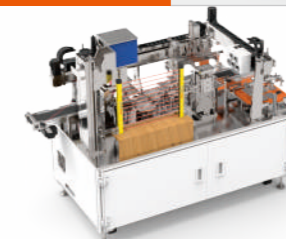

08

Lithium Smart Storage



# Lithium Coating Machine

As the most basic and core part of cell manufacturing, coating machine plays a important role in maintaining the consistency and reliability of finished batteries. To guarantee the efficiency and quality of production, the machine is required to work with a high degree of smooth coating, and be able to change rolls automatically and speedily without stop. It would be more easy to achieve precise control of coating machines with the application of sensors.



## Color/Mark Positioning of electrode

- Color/Mark Sensor  
**ESC Series**
- Combine Color and Mark Modes of RGB
  - Detect with High Sensitivity Even for Subtle Difference in Background Colors
  - Digital Button Design for Sensitivity Adjustments

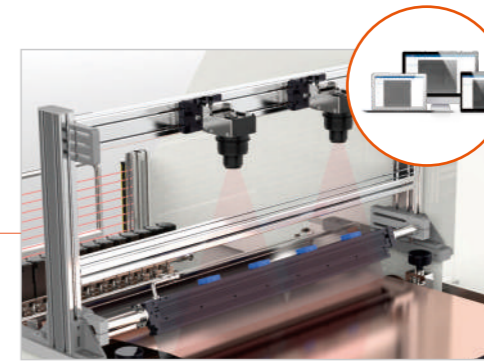

## Defect Detection on electrode

- AI Image Recognition  
**MEIJI AIV Platform**
- Four-pixel Extremely High Definition
  - Pixel-level Detection and Edge Recognition

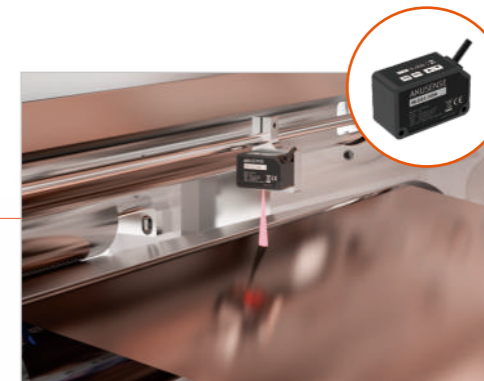

## Detection of Coating Height

- Laser Displacement Sensor  
**MLD23 Series**
- International Advanced R&D Technology and Manufacturing Process, to Achieve Micron-level Detection with High Accuracy
  - One-piece Structure, Compact Size, Simple Installation
  - Linear Accuracy Reaches 0.01mm, Ultra-high Sensitivity with Stable and Precise Measurement Data

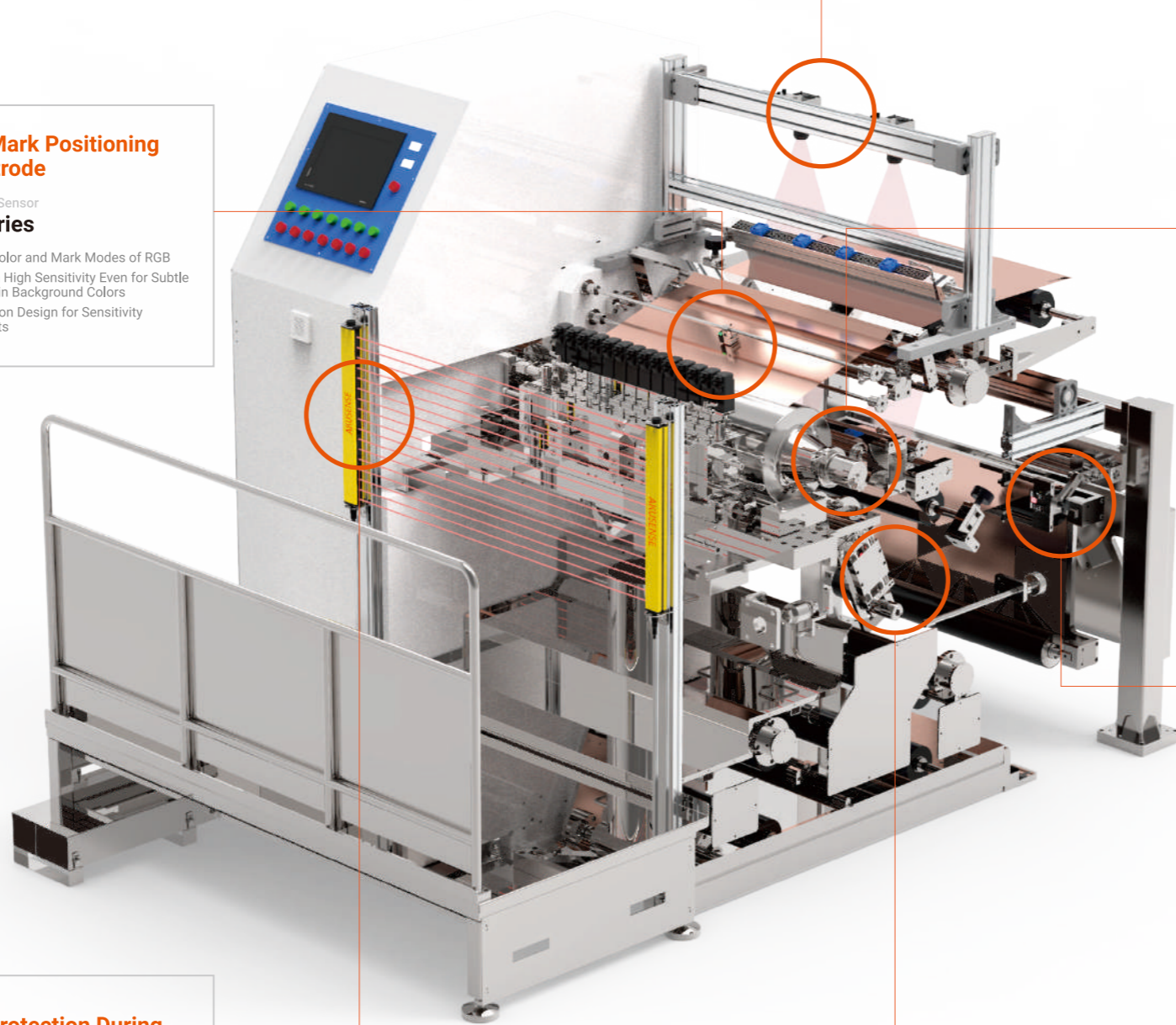

## Real-time Monitoring on the substrate positioning of Positive and Negative Materials

- Thru-beam edge Sensors  
**ETD-0612**
- Repeat Accuracy Gets  $\pm 1\mu\text{m}$
  - Laser Alignment Measurement Principle, Super Stable
  - Integrate Width Mode with Edge Mode, no effect by object colors or materials.

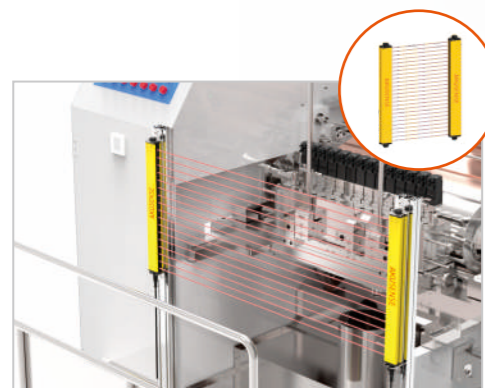

## Safety Protection During Equipment Operation

- Safety Light Curtain  
**SAF Series**
- Detect Objects With Various Sizes, Such as Finger, Palm, Arm and ect.
  - A Variety of Appearances and Sizes, Protective Heights, Detection Methods Are Available



## motion limit detection of cylinder

- Proximity Switch  
**TRN Series**
- Ip67, excellent waterproof and oil-resistance performance
  - Built-in indicator, easy to install and debug



## Safety Protection During Equipment Operation

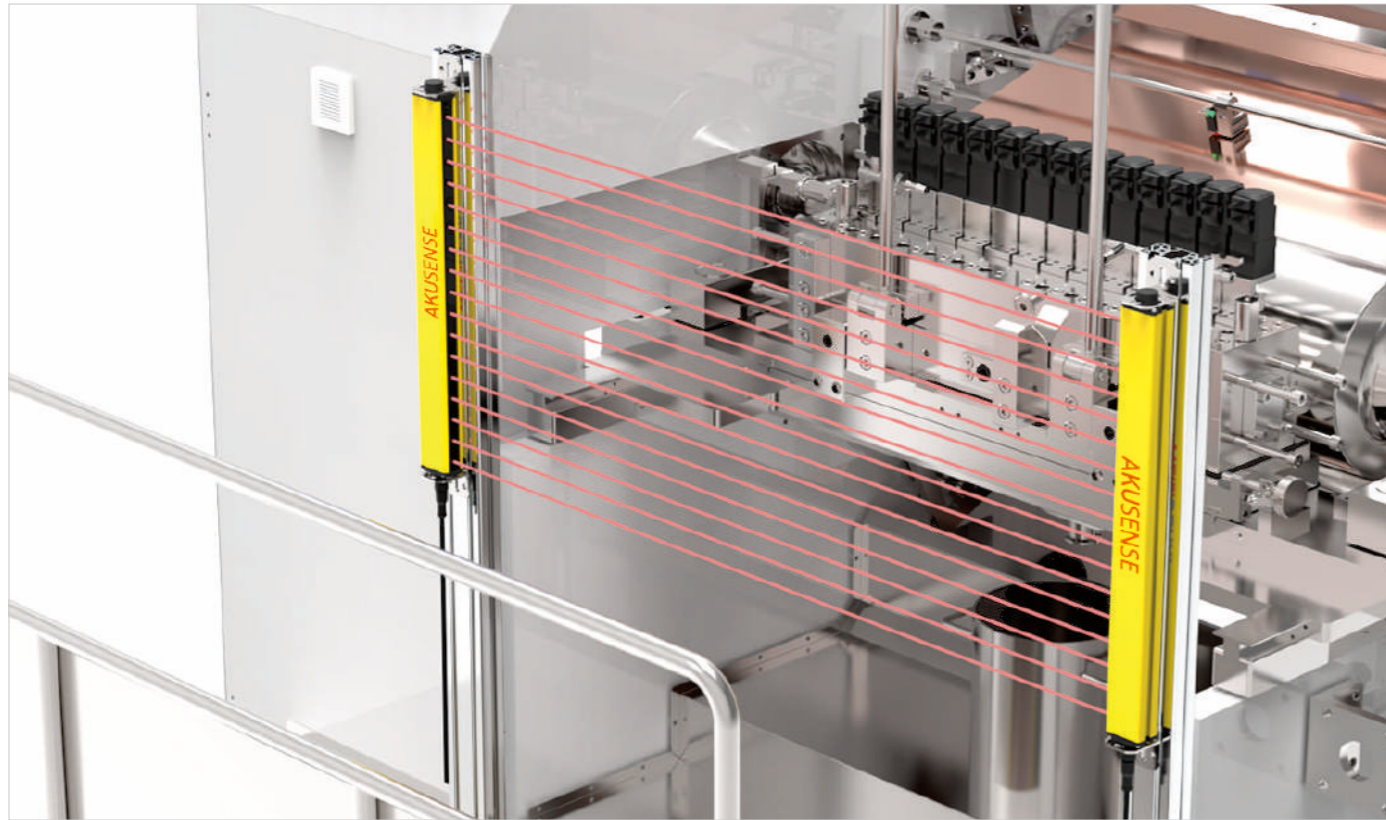

### Safety Protection During Equipment Operation

**Requirement:**

During the process of coating for electrodes with positive and negative materials, it is necessary to stop members entering the areas and getting themselves into potential risks.

**Solution:**

SAF series, type 4 safety light curtain, PLE(safety level), a powerful guardian of industrial safety. Perfect auto-inspection function realizes complete auto-test including signal-output with great shock absorption performance. Suitable for high-speed stamping machines with long duration and high safety performance.

## Real-time monitoring for the substrate position of Anode and cathode materials

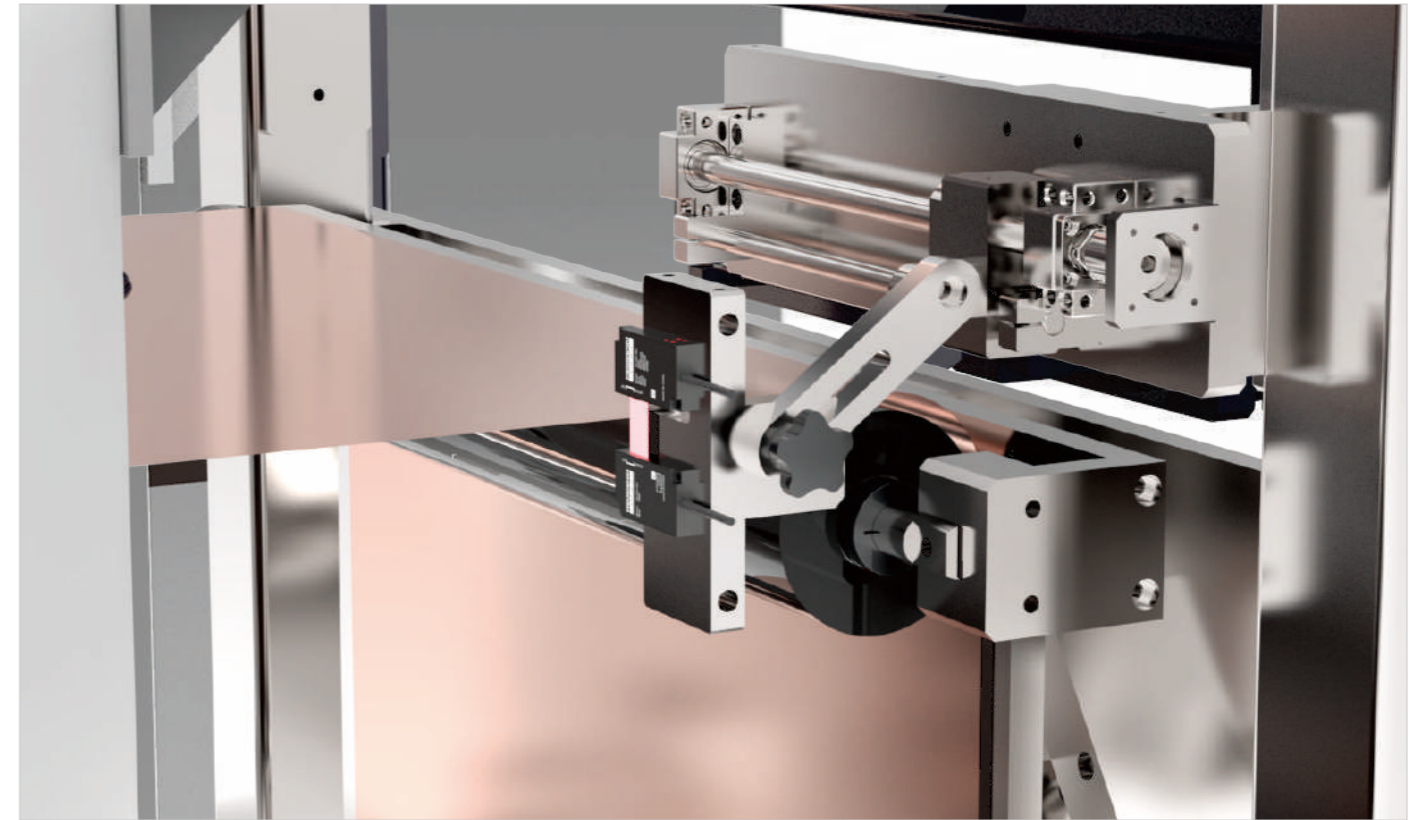

### Real-time monitoring for the substrate position of Anode and cathode materials

**Requirements:**

In the coating process, it is required to take real-time monitoring on position deviation for the substrates of positive and negative materials, to avoid uneven coatings caused by deviation when they are on conveyors.

**Solution:**

ETD-0612, new laser deflection sensor, installed at the edge of the substrate, directly communicates with PLC via analog output; real-time monitoring of the left or right deflection of substrate edge, which can realize micron-level position measurement. Adopting the principle of laser area thru-beam detection, it covers a range up to 12mm wide.



# Lithium Winding Machine

Lithium-ion battery winding machine is used to wind lithium-ion battery cells. The winding machine has positive and negative feeding units, the part wound together by positive and negative poles is called winding needle. Important components of the lithium-ion battery winding machine include the frame, winding device, pole-piece supply device, auxiliary pressure-plate and cutting device, tape-supply device, electrical control and so on.

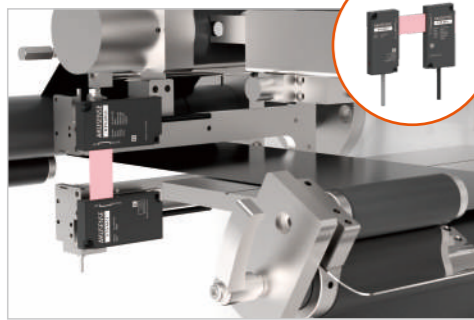

## Diaphragm Transmission Deskw

Deskw Sensor  
**ETD-0612**

- Repeat accuracy  $\pm 1\mu\text{m}$ , high stability with laser thru-beam measurement.
- Designed with both width and edge detection modes for edge control and positioning.

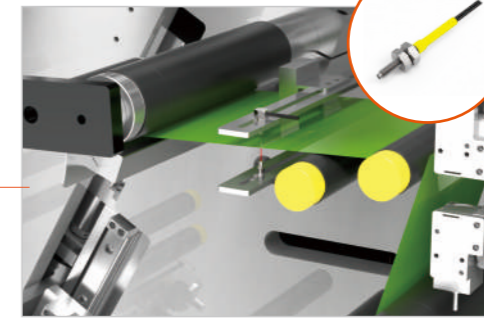

## Monitoring on electrode and diaphragm transmission

Fiber Optic Amplifier and Fiber Optic Components  
**PG1+PD-32**

- Fiber optic components with a full range of specifications, which can realize the replacement of the mainstream models in the market.
- Dual digital amplifiers with automatic light compensation for high precision.

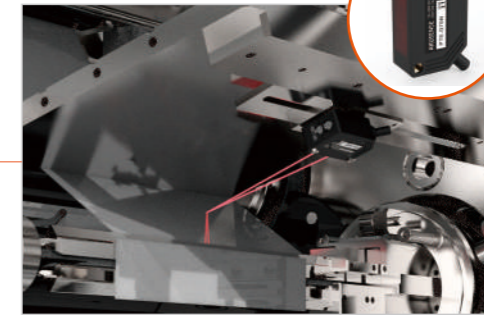

## In-place Detection for Battery cell coil materials

Square Photoelectric Sensor  
**PTE-D70N**

- Response time < 1ms, Normal Open and Normal Close for Option
- Simple to install with M3 standard threaded holes



## cylinder module limit

Magnetic Sensors  
**MR-C8-U-S**

- High positioning accuracy and great performance
- 5us extremely fast response time

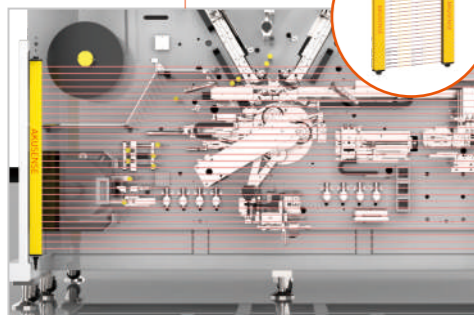

## Device Security Protection

Safety Light Curtains  
**SAF Series**

- Type-4 safety certificate by TUV, greatly enhancing production safety
- Mechanical architecture design, compression resistance, anti-vibration, and shock resistance.

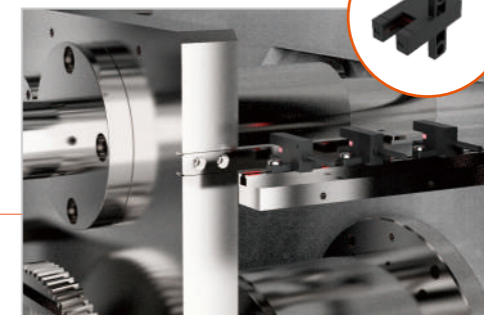

## Motion Mechanism Limit

Slot Sensor  
**ST-303N-W**

- Chip integrated design, repeatability up to 0.01mm
- Normally open and normally close, outputs can be switched with stable performance.



## Monitoring on electrode and diaphragm transfer

### Transfer deflection of diaphragm

#### Monitoring on electrode and diaphragm transfer

##### Requirements:

During the production process of electrode winding, it is needed to take real-time monitoring on battery's positive and negative electrodes as well as diaphragm transfer, avoiding interruptions in following processes due to material shortages.

##### Solution:

Fiber optic sensors, installed above or below these materials, provide real-time monitoring and feed the signal back to the PLC for control; a variety of fiber optic components and dual digital amplifiers can be used together to meet the installation requirements for several workstations simultaneously.

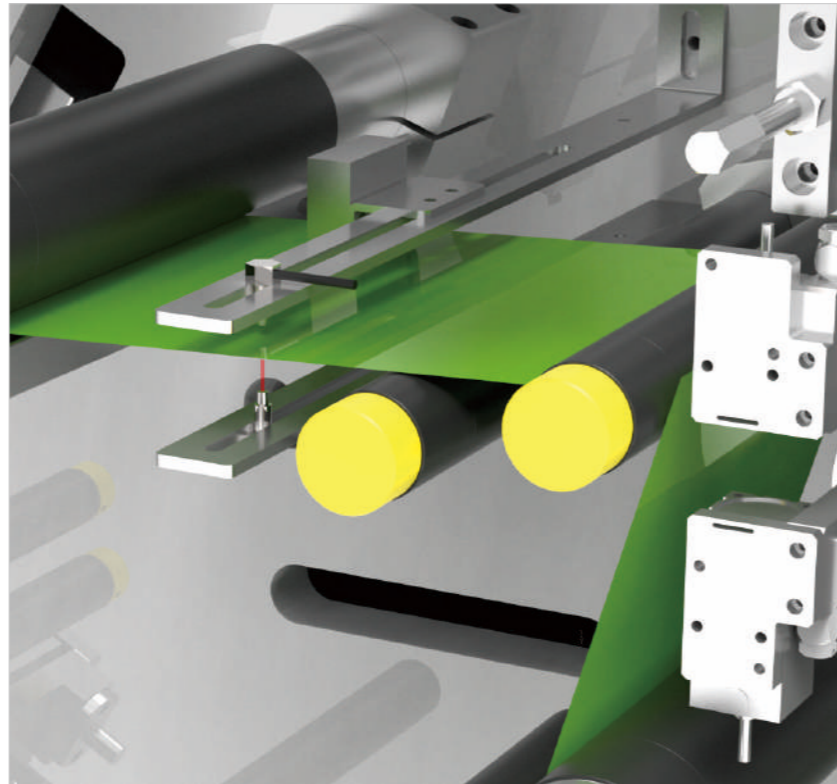

## Motion mechanism limit

#### Motion mechanism limit

##### Requirements:

Real-time control of device motion and position limit.

##### Solution:

Akusense produces a wide range of slot sensors. With the design of chip integration, position control on devices taken with higher precision, as the repeat accuracy reaches 0.01mm. Various appearance designs and installation methods to meet the different needs of position measurement.

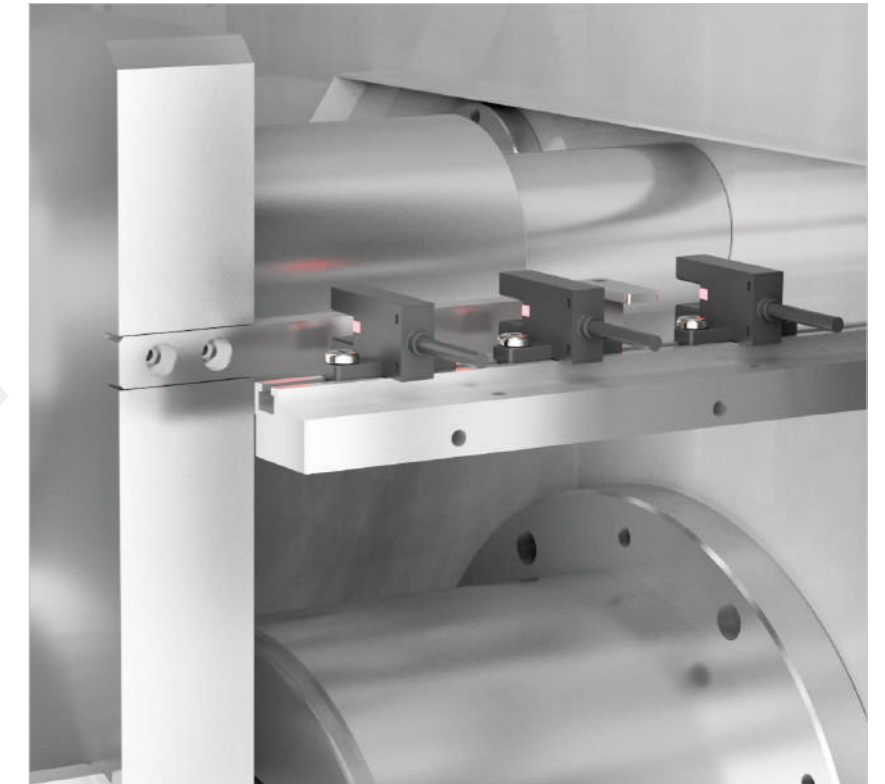

#### Transfer deflection of diaphragm

##### Requirements:

Real-time monitoring taken on winding machines to control the left or right deviation during the process of diaphragm transfer, and the deviation value will be released to the system designed, aiming to realize the positioning control precisely. The accuracy will be as high as silk-level to guarantee the consistency of the winding.

##### Solution:

The latest edge sensor ETD-0612 by Akusense adopts thru-beam reflection, achieving precision control as high as 1μm. At the same time, this product outputs analog voltage signals to directly interact with the deflection system of equipment, realizing real-time control of diaphragm position.

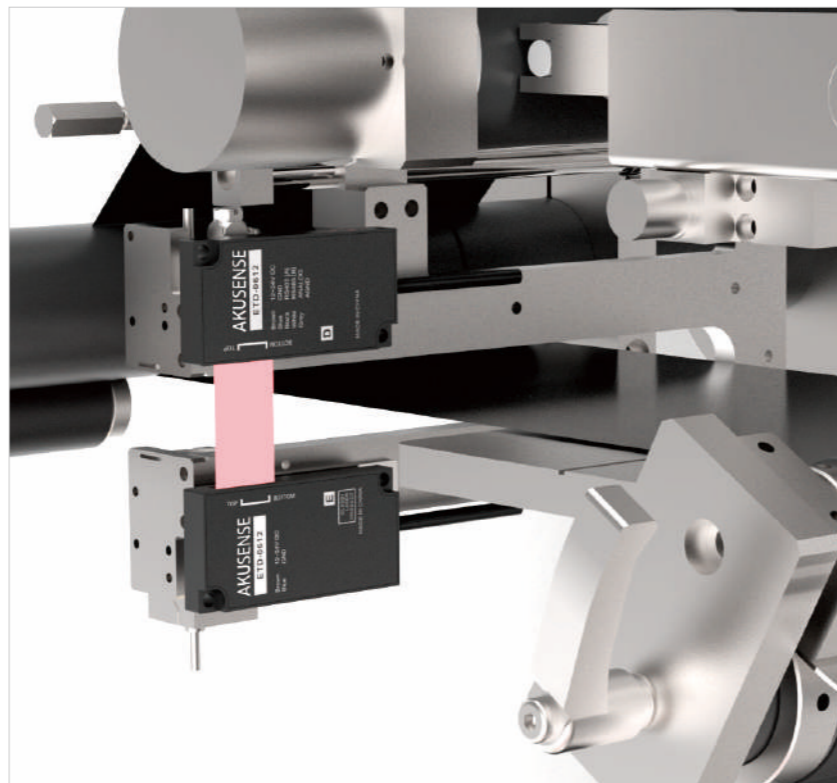



# Lithium Laminating Machine

Lithium laminating machine is one of the key devices for battery production in this industry. It belongs to the middle process of manufacturing, specifically the electrode assembly process. Its main function is to assemble and stack the positive and negative electrodes of the lithium battery cell with the separator in a Z-shaped manner to form a small cell unit, and then stack and connect the small cell units in parallel to form a large cell.

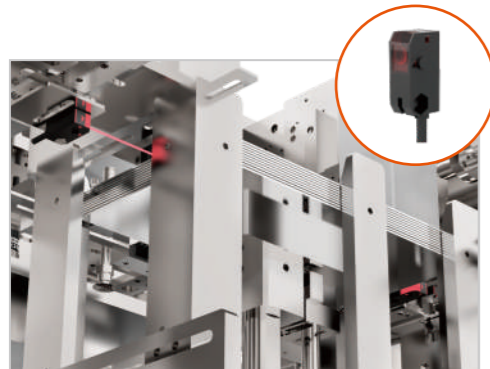
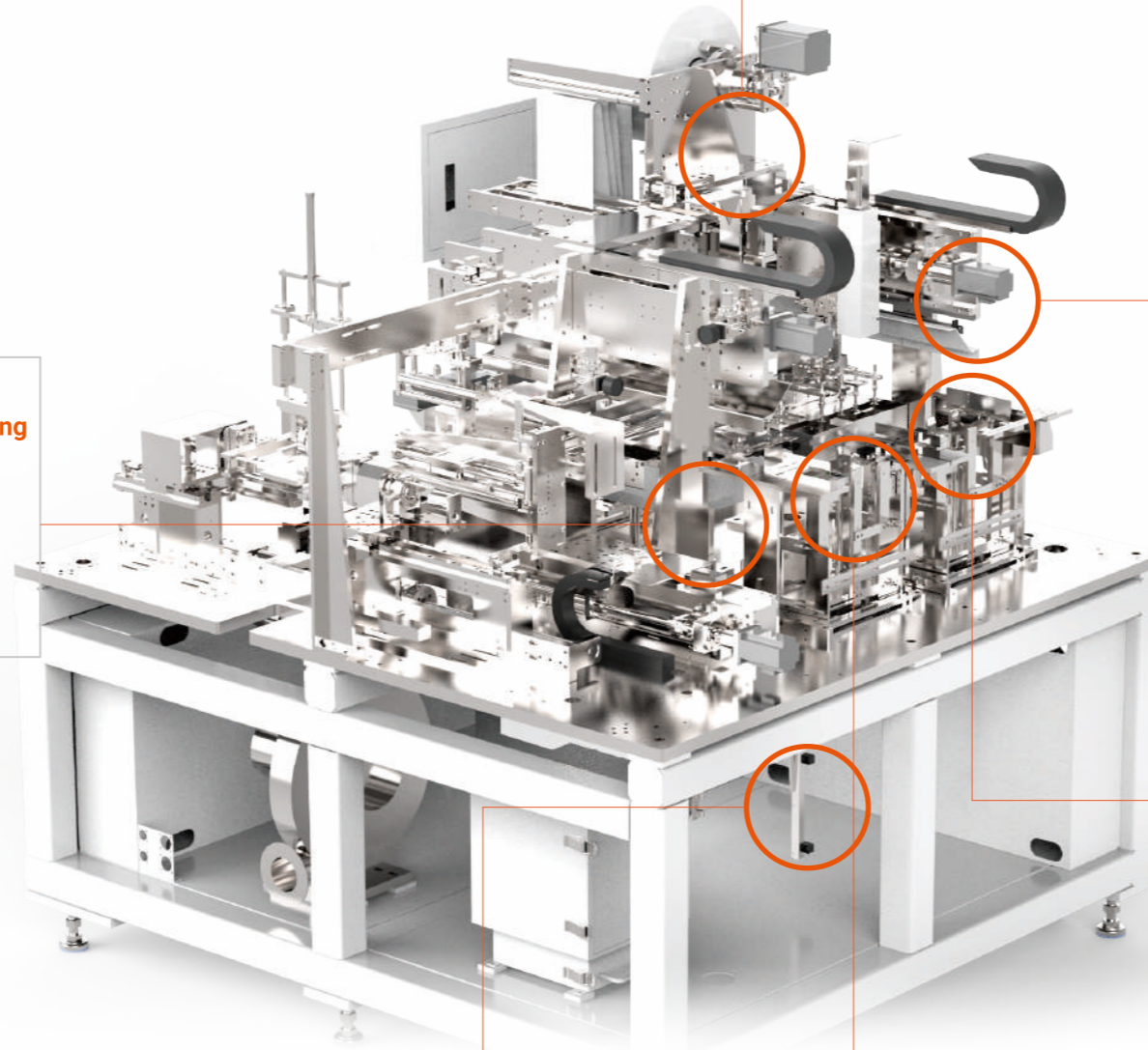

## Battery electrode positioning

- Thru-beam Photoelectric Sensor  
**PTJ Series**
- L.on (light-on)/D.on (Dark-on) switchable, sensitivity adjustable, size as compact as a little finger
  - Dual LED indicators, clearly recognize operating state



## Residual Material Monitoring on diaphragm

- Laser Displacement Sensor  
**MLD23 Series**
- Ultra-fast computing and processing, with a response time of 1.5ms.
  - High-resolution lens achieves a repeat accuracy of 0.01mm.

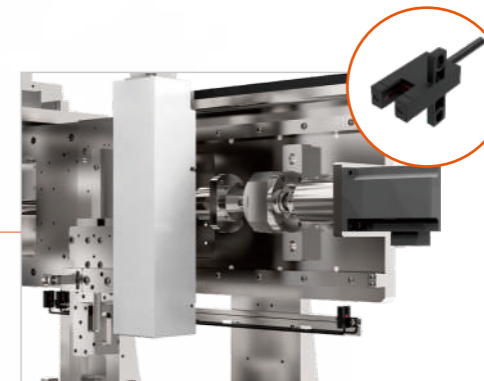

## Mechanical limit

- Slot Sensor  
**ST-303N-W**
- High repeat accuracy achieves 0.01mm, normally open and close switchable.
  - A wide range of options, including 12 different appearances such as F/T/R/L/K/T.

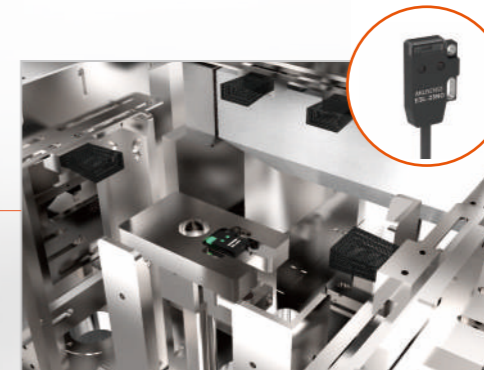

## Residual material monitoring on electrode

- Ultra-thin Photoelectric Sensor  
**ESL-25NO**
- 3.5mm of thickness and saves installation space.
  - IP67, excellent performance.



## Material Box Limit Control

- Square Proximity Sensor  
**TQF18-05NO**
- High repeat accuracy <1.0% (Sr), switching frequency 1KHz
  - IP67, effectively enhance product performance

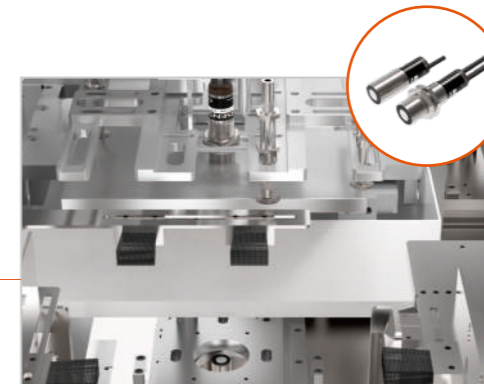

## Single and double sheet detection for electrode

- Single And Double Sheet Detection Ultrasonic Sensor  
**MUD Series**
- 3 control input, choose related mode (thick/thin/standard) based on object thickness.
  - Stably detect paper/metal/plastic/platinum/silicon wafer/battery electrode.



## Single or double sheet detection for electrode Battery electrode positioning

### Double sheet detection for electrode

#### Application:

It is required to detect the positive electrode and negative electrode in stacking machine before stacking, to avoid overlapping and causing the safety hazards in the cells.

#### Solution:

Akusense MUD series double sheet detection sensor. It stably detects single sheet or double sheet by using ultrasonic technology. In above application, MUD series sensor can detect the overlapping or shortage of the electrode according to the signal intensity of sound wave on the receiver. It supports multiple detection model and self learning. It is possible to teach in according to detected objects, allowing the sensor to detect single sheet or double sheet for various materials with various thickness.

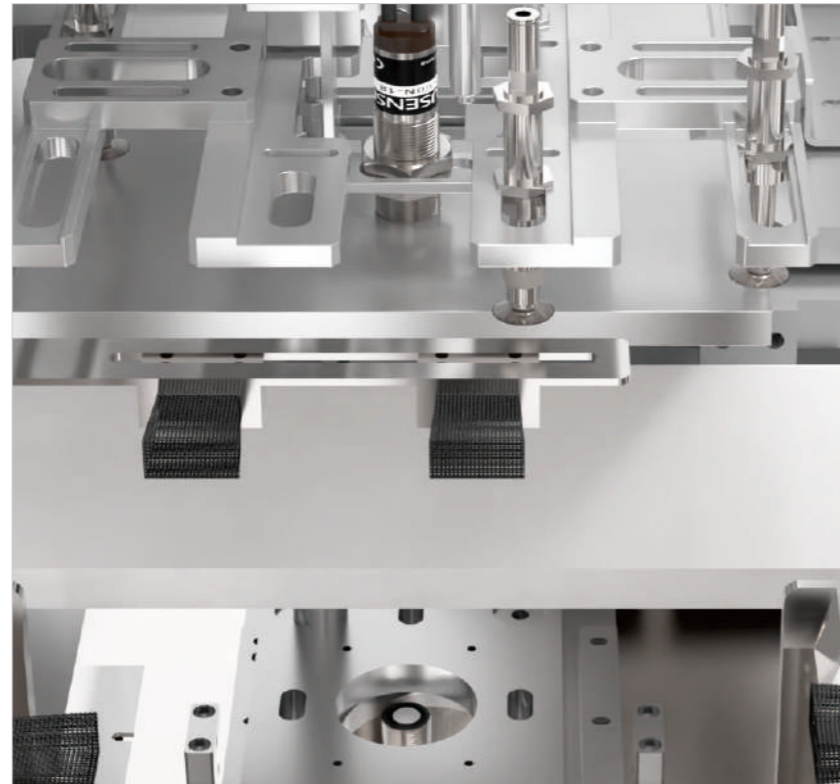

## Surplus materials detection on diaphragm

### Surplus materials detection on diaphragm

#### Application:

It is required to detect the surplus material of the lithium battery diaphragm on the stacking machine. When the diaphragm material roll is almost run out of, the sensor will give signal to the equipment to response, reminding the operator to replace the material roll in Application time.

#### Solution:

Akusense MLD23 series displacement sensor. Through triangulation method, the sensor can realize high precision detection. The max. sensing distance is 280mm, can meet diameter measurement requirements for diaphragm rolls in different specifications. Equipped with 0-5V voltage output and 4-20mA current output, the sensor can interact with the PLC to do real time detection.



### Battery electrode positioning

#### Application:

To detect the position of positive and negative electrode in loading process. When electrode reach to the set position, the sensor will give signal to the robotic manipulator to material.

#### Solution:

PTJ series photo sensor can be installed on both sides of the workstation to do the task. The size is as big as a finger, which can be installed in compact space in loading station. It adopts invisible infrared light source, with no effect on the photo sensors and equipment operators.

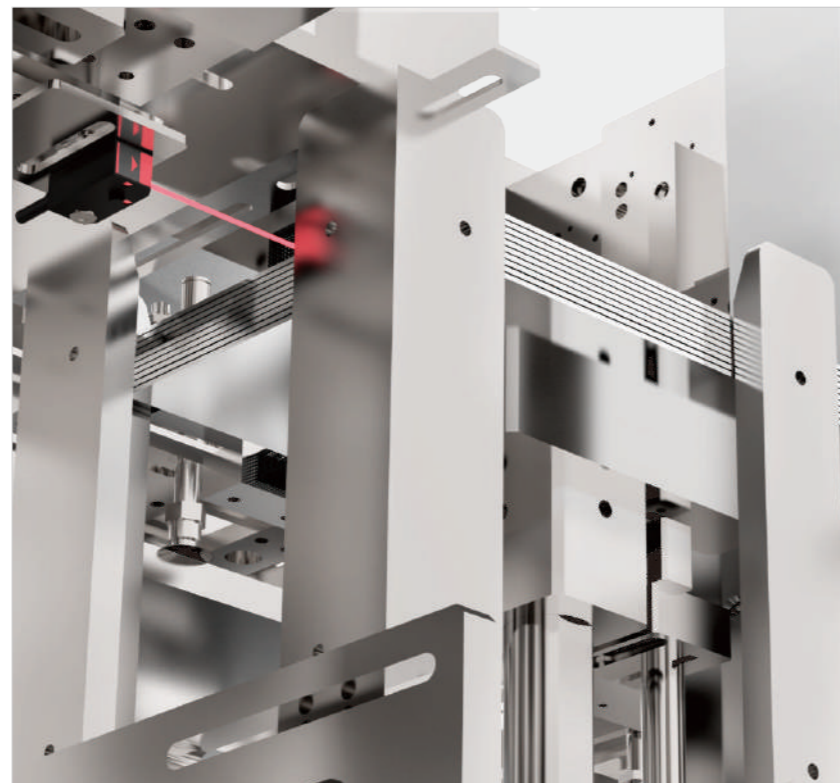



# Lithium Coating Machine

In order to prevent surface scratches and leakage of lithium batteries during transportation and assembly, lithium battery coating equipment is generally used to wrap a layer of insulating film with one side adhesiveness on the surface of the battery, which can be waterproof and dustproof, for better protection on the battery.



**Material detection on conveyor**

BGS Diffuse Reflection Photo Sensor  
**ESB-V30N**

- Infrared light source, strong anti-light interference capability
- Response times 2ms



**Gripping process**

BGS Diffuse Reflection Photo Sensor  
**ESB-30N**

- 15% black and white difference, any color background and object can be detected stably
- 6-turn potentiometer for fine adjustment of sensitivity



**Surplus material detection on tape**

Amplifier And Fiber Unit  
**PG1+PD-32**

- 4 speeds for option
- Built-in light compensation, small hysteresis, dual output



**Mechanism positioning**

Slot Sensor  
**ST-303N-W**

- All-in-one design for chip, repeat accuracy is up to 0.01mm
- The slot is as deep as 8.5mm, preventing the object from hitting the bottom of the slot and causing hardware damage.

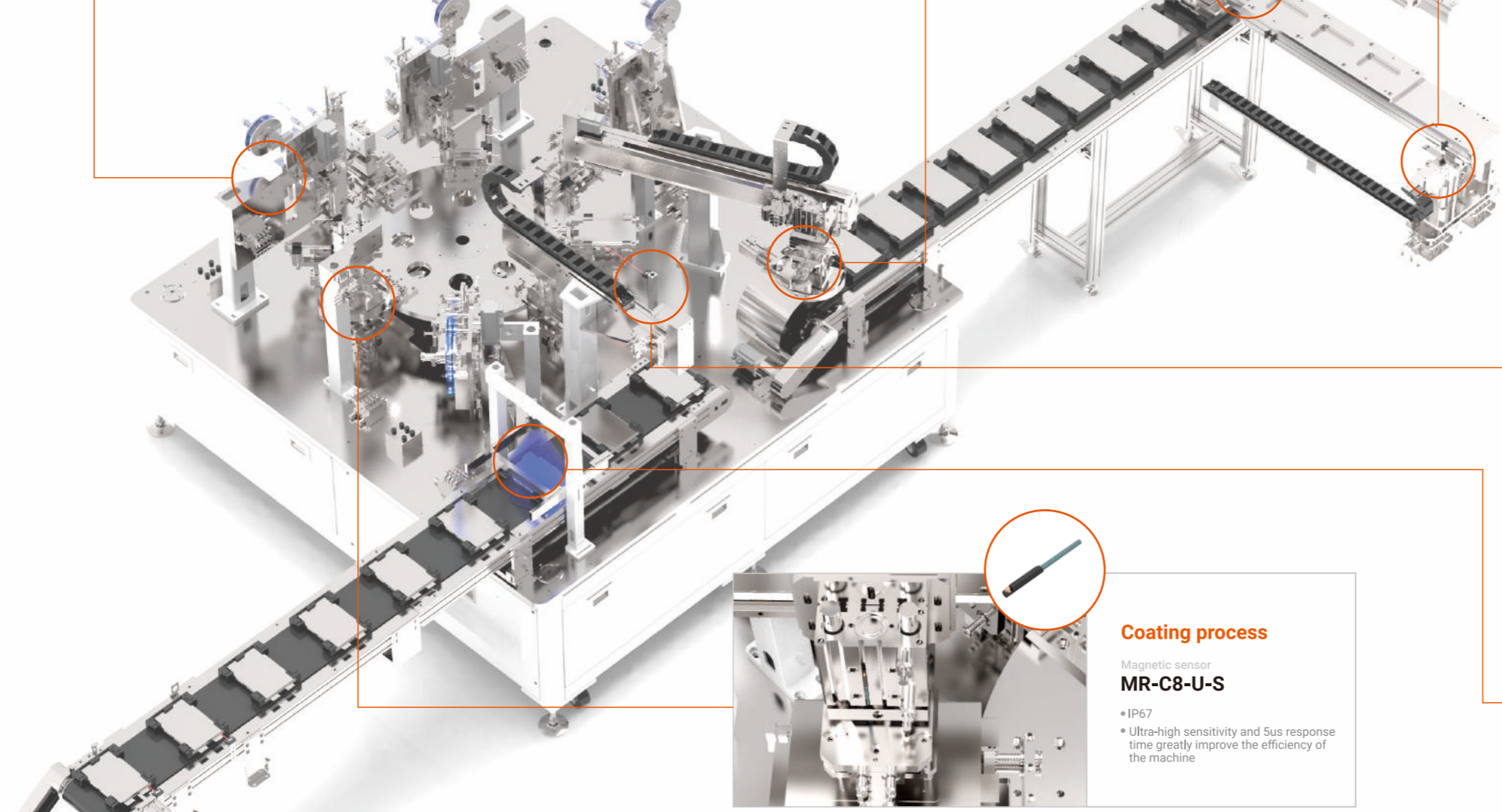

**Turntable processing station**

BGS Diffuse Reflection Photo Sensor  
**ESB-30N**

- 15% black and white difference, any color background and object can be detected stably
- 6-turn potentiometer for fine adjustment of sensitivity

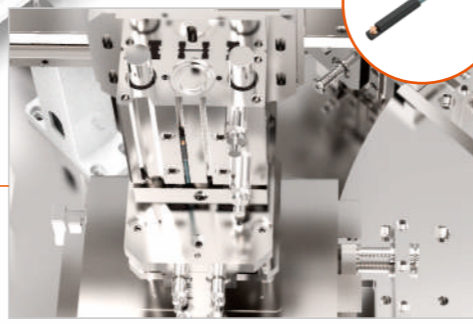

**Coating process**

Magnetic sensor  
**MR-C8-U-S**

- IP67
- Ultra-high sensitivity and 5us response time greatly improve the efficiency of the machine

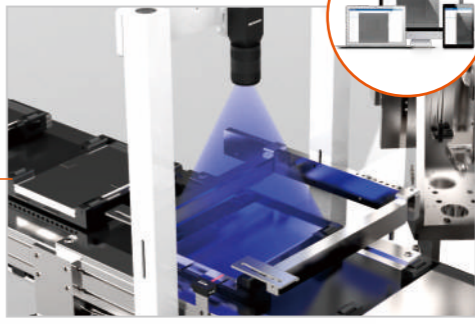

**Defect detection**

AI Image Recognition  
**MEIJI AIV Platform**

- Process visualization, good product experience
- Test results are clear at a glance, fast project delivery



## Defect detection Wrapping station

### Defect detection

#### Application:

Camera inspection is a key part of the quality inspection of the coating. At this station, the camera needs to detect defects for the coating. Those products with wrinkles, bubbles, scratches and other undesirable defects or products that do not meet the requirements will be recorded and pick out.

#### Solution:

When the bottom diffuse reflection photoelectric sensor ESB-V30N detects that the coated battery on the material tray is in place, it immediately triggers the vision camera to take pictures for comparison. The defective products are recorded and picked out. The meiji AIV system equipped with the camera has 100 million pixels of super image processing capabilities. It is easy to use and can complete the training and deployment of AI models with simple operations, and seamlessly connects with production line equipment.

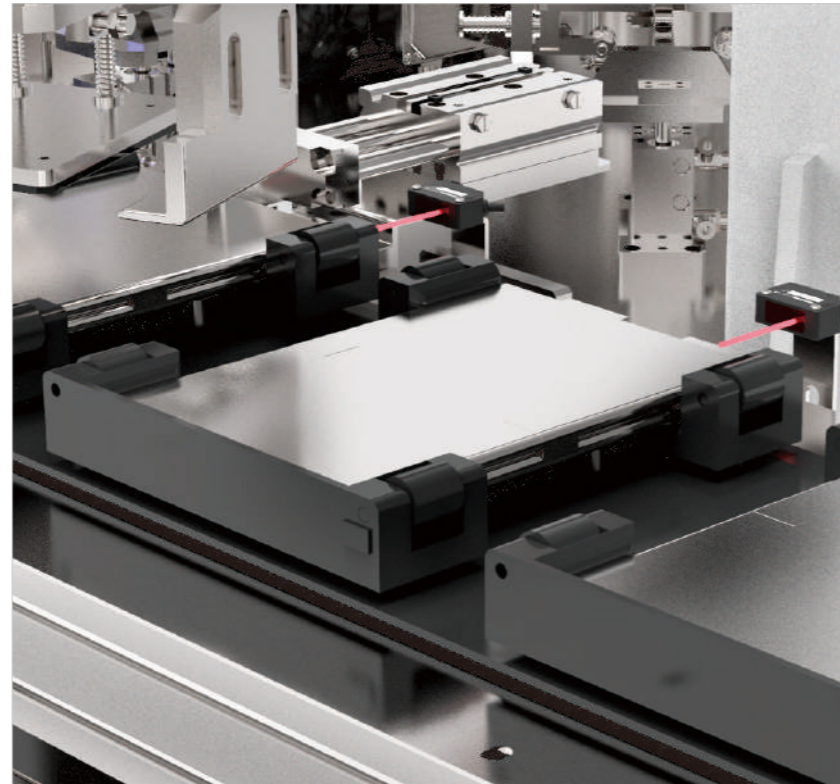

## Turntable processing station

### Turntable processing station

#### Application:

Each processing station on the turntable is equipped with a sensor to detect the position of the battery and perform coating processing.

#### Solution:

BGS diffuse photo sensor ESB-30N is installed on each turntable station. As it is not affected by any color and has superior mechanical properties, it can effectively solve the detection of material in place in multiple scenarios. Even if the background of the station is very complex, it can detect accurately and stably.

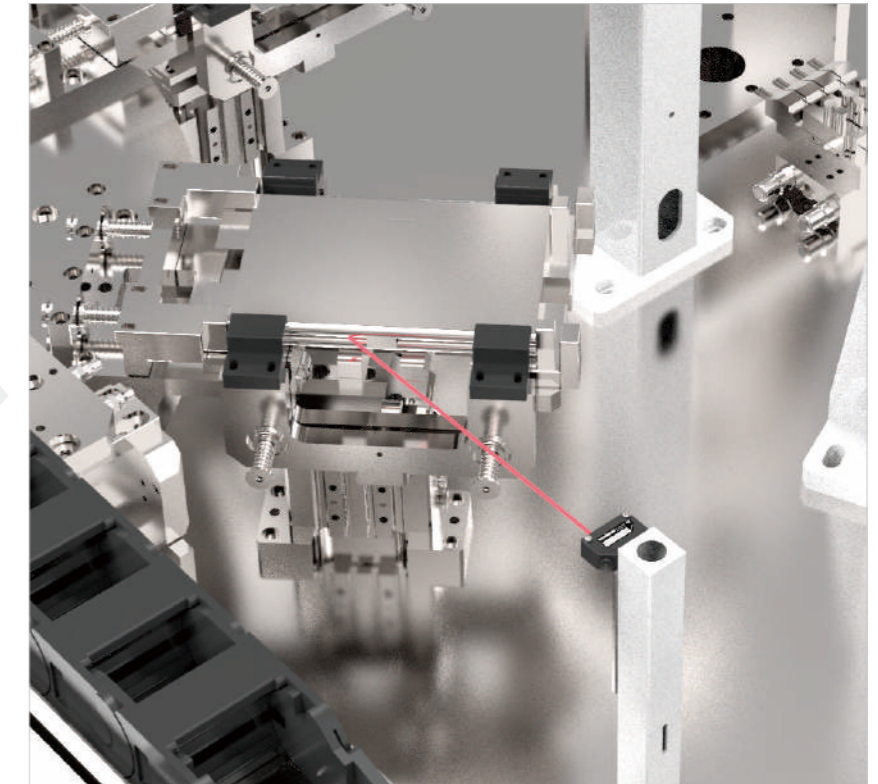

### Wrapping station

#### Application:

When the lithium battery reaches the station, the sensor senses that the material is in place to drive the upper cylinder to compact the film.

#### Solution:

The ultra-high-precision magnetic sensor MR-C8-U-S can be installed here to detect the position of the cylinder and give a signal to retract the cylinder to proceed with the next operation; With high sensitivity and 5us response time, it can greatly improve the operating efficiency of the machine.

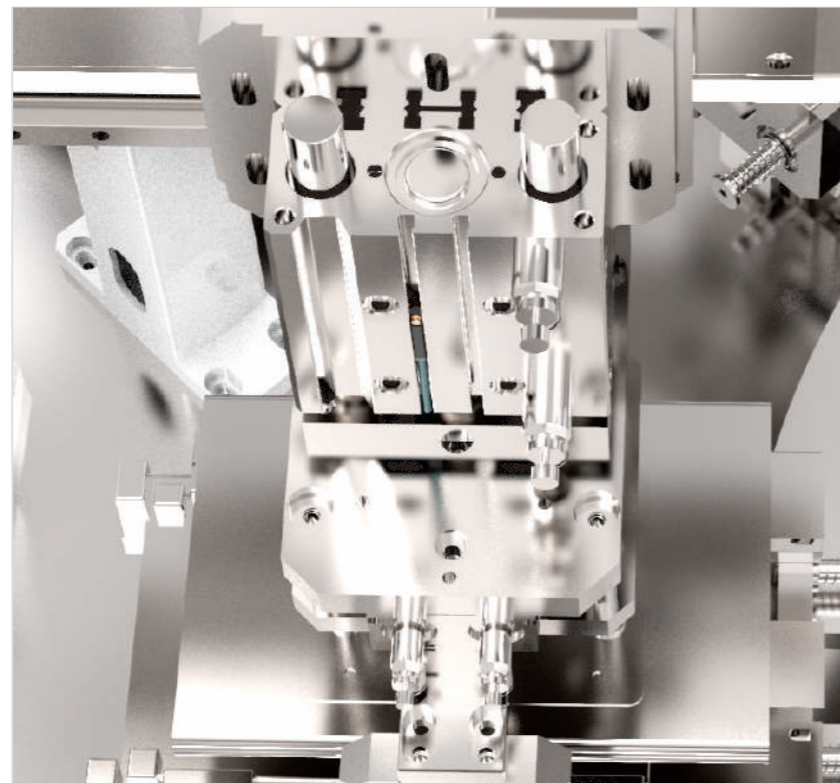



# Lithium Tab Cutting Machine

In the production process of lithium-ion batteries, cell tab cutting is an important process. During the battery cell manufacturing process, due to the size differences between different tabs, the front ends of the tabs are uneven after pre-welding of the multi-layer tab stacks. In order not to affect the subsequent cover welding and other processes, the uneven tabs need to be cut. lithium-ion battery tab cutting equipment is created to fulfill this task.

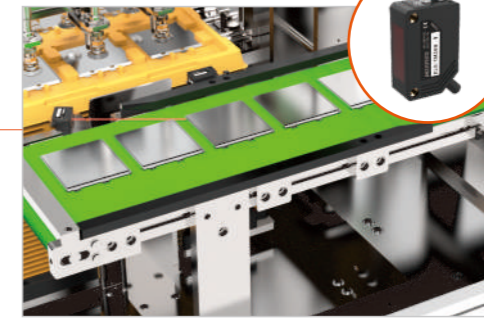
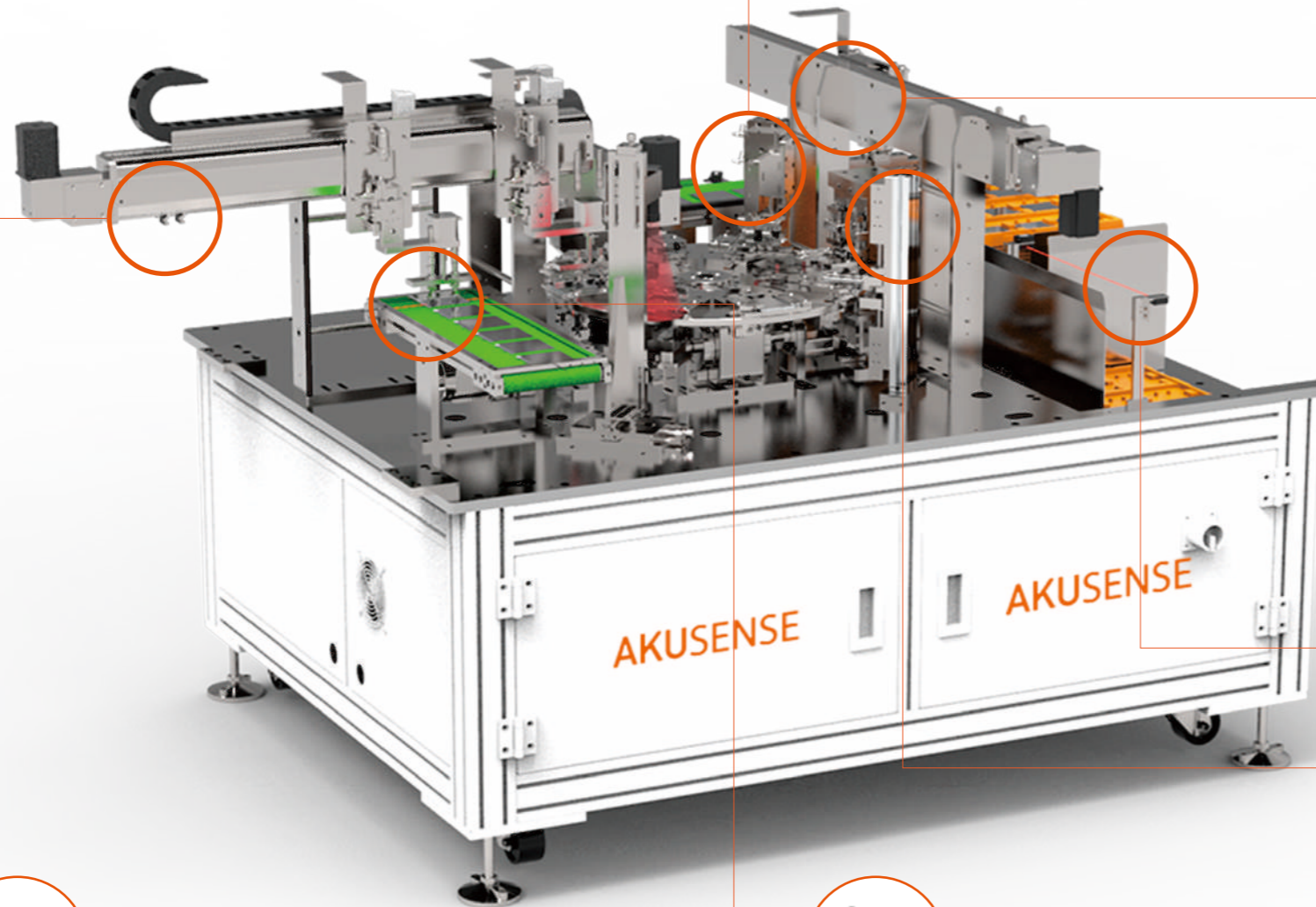

## Gripping process

Laser Sensor  
**ELE-TM30N**

- 30m sensing distance, with 1mm light spot at 500mm
- Classic square design, easy to use

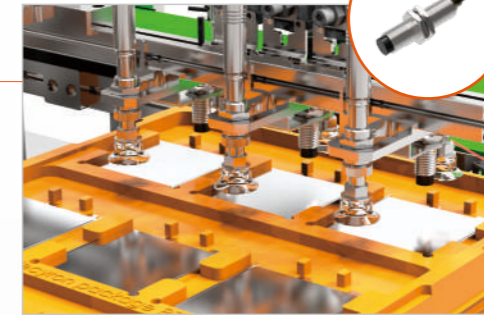

## Detect the presence of cell

Proximity Sensor  
**TRN Series**

- IP67
- Built-in clear indicator, easy to install and debug

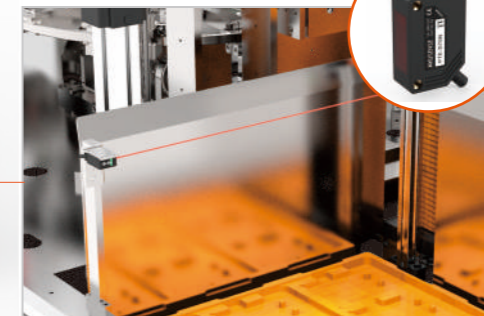

## Material tray positioning

Photo Sensor  
**PTE-D70N**

- Adopts advanced self-developed anti-interference algorithm with excellent stability
- Multi-view indicator display, trimmer for sensitivity adjustment, easy to use

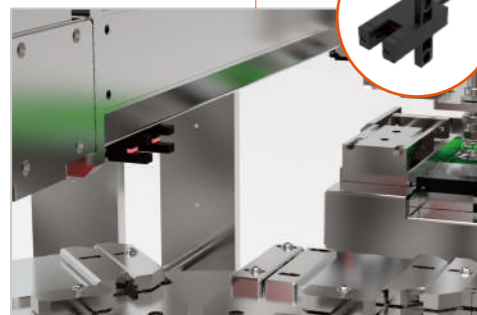

## Control the origin position of the manipulator

Slot Sensor  
**ST-303N-W**

- All-in-one design for chip, ensure the superior consistency
- Designed with line protection, reverse connection protection, overload protection, etc.

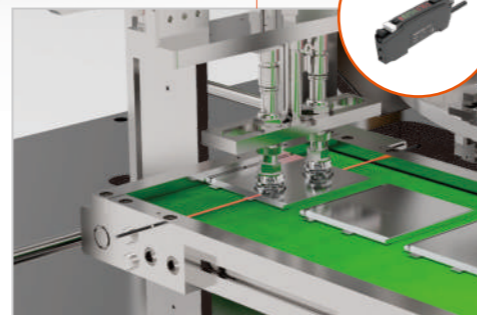

## Cell detection in unloading process

Fiber Sensor  
**PE1+PD-32**

- One button to teach-in, user-friendly
- More stable high-speed mode greatly improve the accuracy

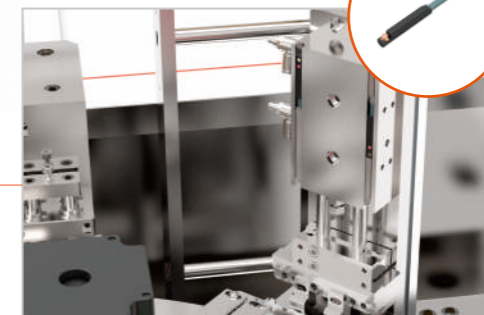

## Mechanism positioning

Magnetic Sensor  
**MR-C8-U-S**

- High accuracy, reliable performance
- 5us response time



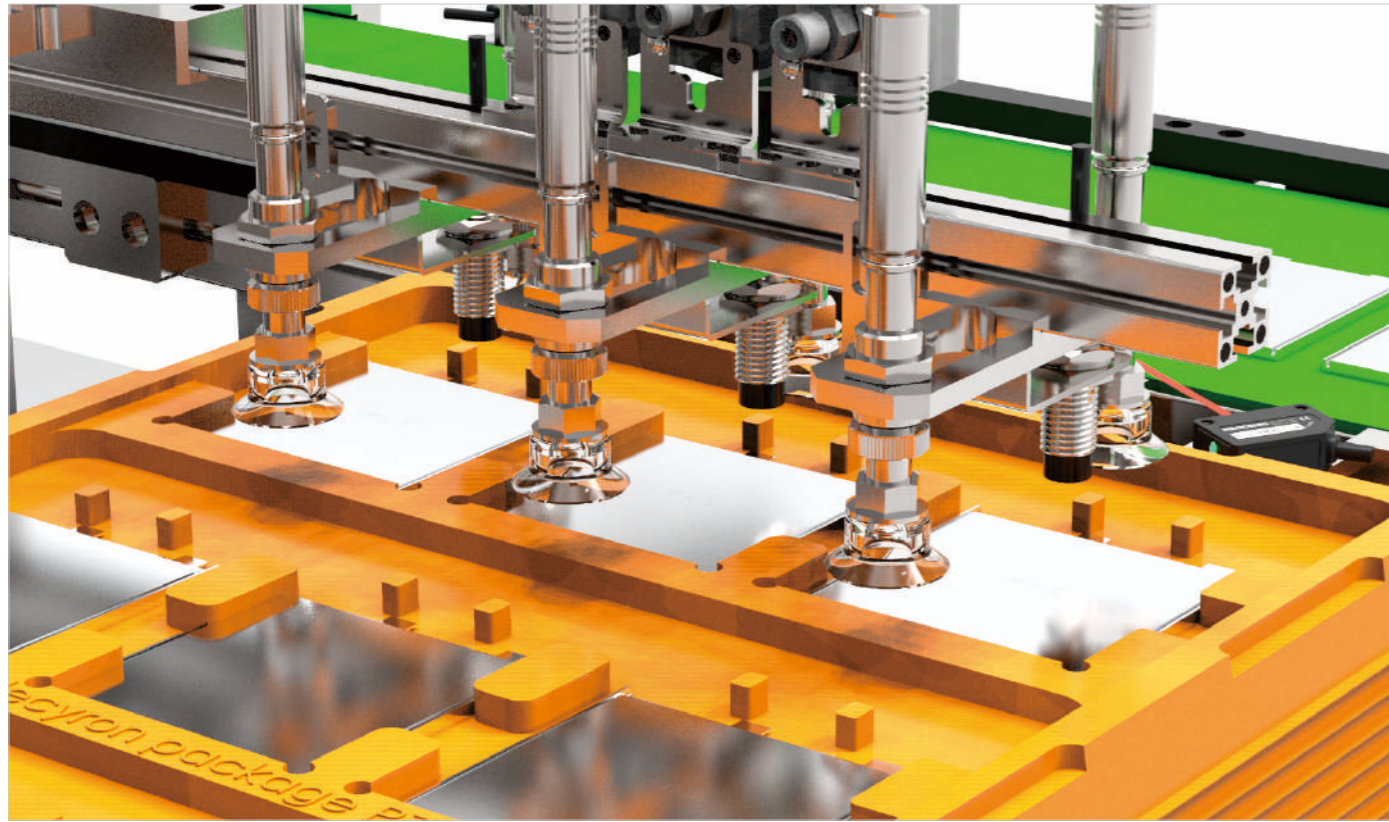

### Detect the presence of cell in materials tray

**Application:**

During the cutting process of battery tabs, it is required to detect the presence of batteries in the tray. When there are lithium battery core materials in the three adjacent bins in the three boxes on the material tray, the equipment controls the manipulator to grip materials directly above the material tray.

**Solution:**

In this process, the TRN series of inductive proximity switches can be used to detect the presence of battery cells. The sensor has 4mm sensing distance, and the attenuation on the battery core is not less than 1.5mm, which can meet the installation requirements on the manipulator of the robot; Akusense proximity switch equips international high-quality magnetic cores, ensuring excellent product performance and long-term stability.

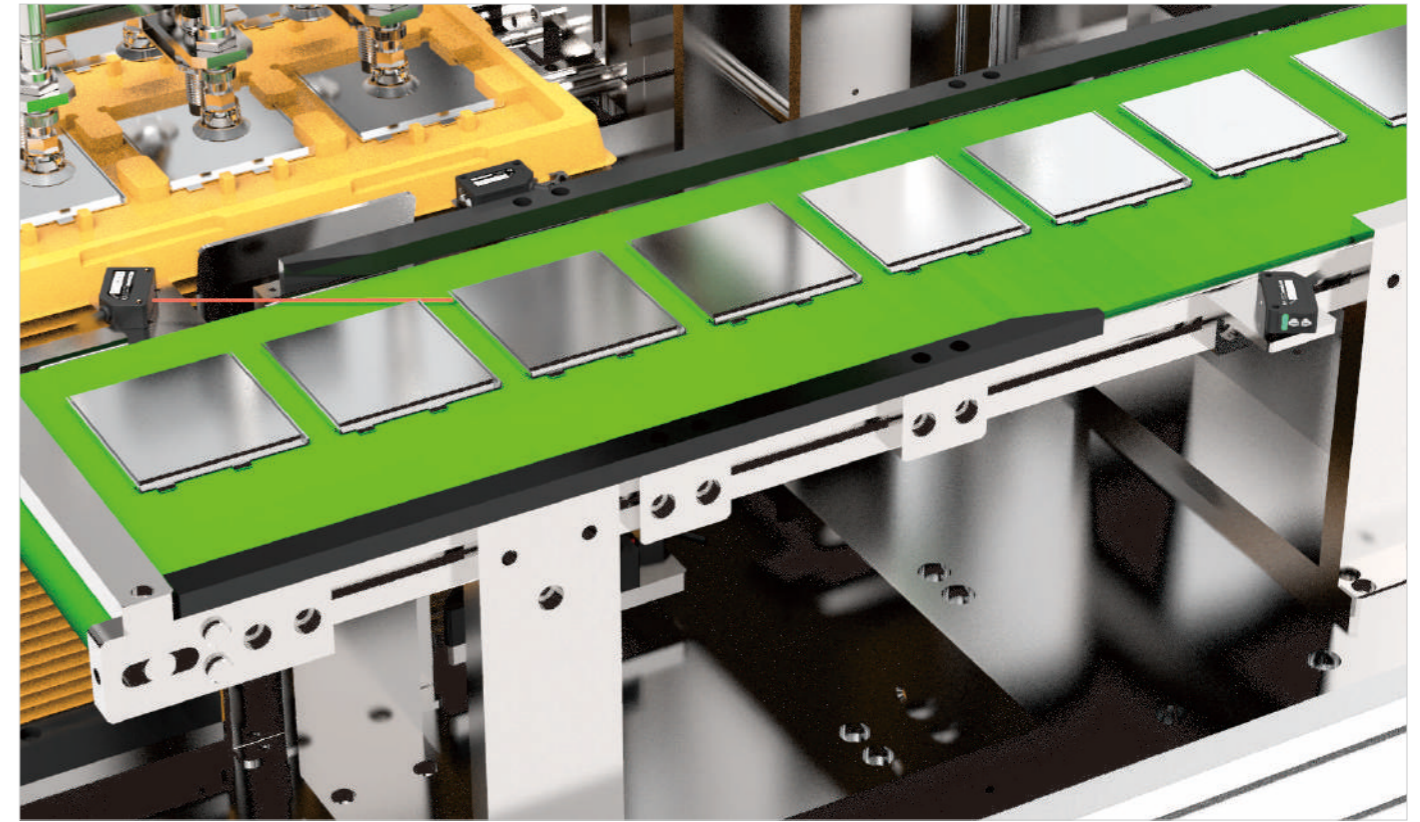

### Gripping process

**Application:**

To detect the presence of the battery core on the feeding conveyor belt of the equipment. When the position sensor detects that the battery core has been transferred, the sensor will output a signal to drive the manipulator to grip the battery core for the next time.

**Solution:**

Akusense through-beam laser sensor ELE series uses laser light source, with a spot diameter as small as about 1mm, and can detect small cells with a thickness of only a few millimeters; The bright signal indicator light and adjustment trimmer make it easy-to-use. It is a very cost-effective solution.



# Lithium Shelling Machine

This equipment is mainly responsible for the casing process of prismatic lithium-ion batteries. It is used to install the bare battery top core into the aluminum shell, press-fit it flatly, and pre-weld the top cover of the battery core to the aperture of the aluminum shell.

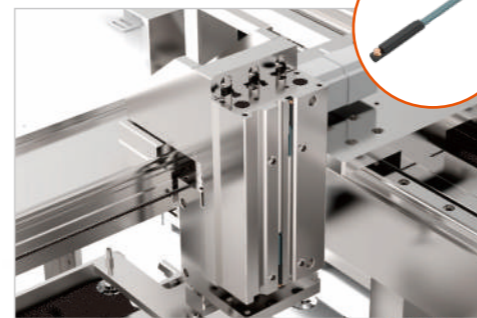

## Station status monitoring

Magnetic Sensor  
**MR-C8-C-S**

- IP67
- Ultra-high sensitivity and 5us response time greatly improve the efficiency of the machine

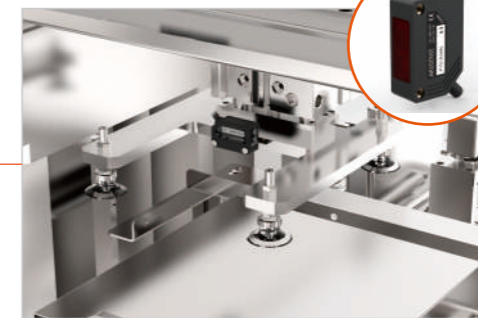

## Aluminum shell dust removal

Convergent Reflection Photo Sensor  
**PTE-X09N**

- Adopts advanced self-developed anti-interference algorithm with excellent stability
- Multi-view indicator display, trimmer for sensitivity adjustment, easy to use

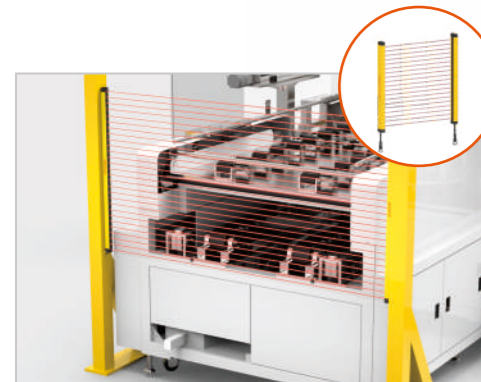

## Area protection around manipulator

Safety Light Curtain  
**BZL Series**

- Thin type safety light curtain, 1/2 smaller than ordinary light curtain, easy to install
- Millisecond response time, multiple beams and beam pitches for option

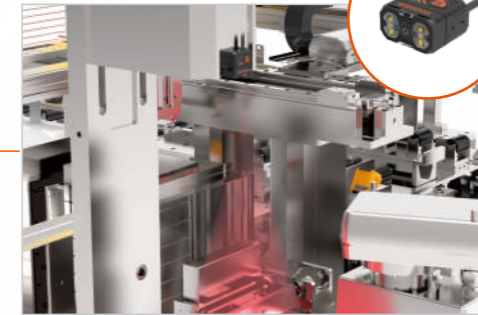

## Cover plate detection

Vision Sensor  
**VDS10 Series**

- Liquid focus technology
- High-precision positioning algorithm and detection algorithm
- Modular solution with integrated light source

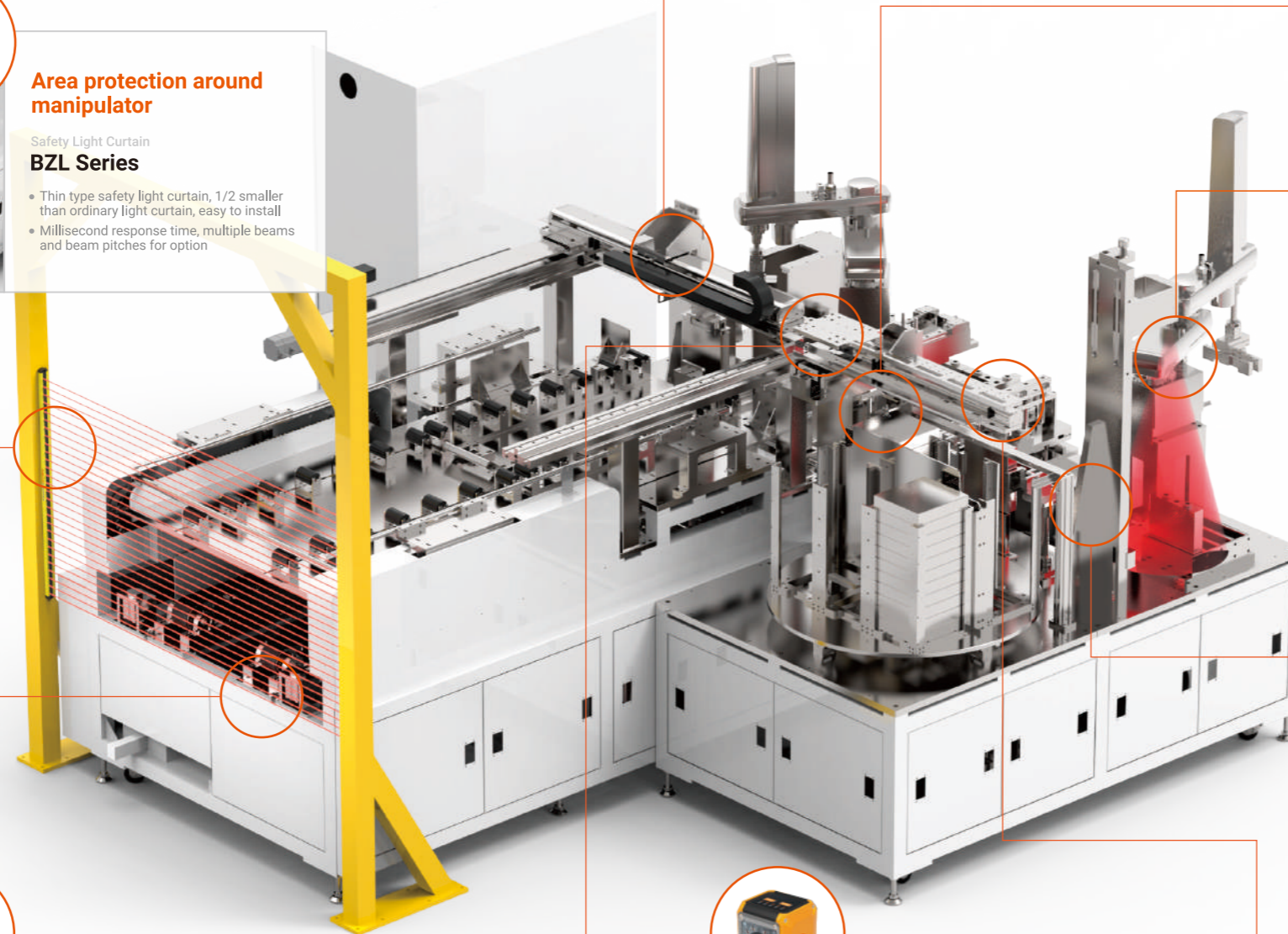

## Aluminum shell positioning

BGS Photo Sensor  
**ESB-V30N**

- Excellent background suppression performance, not afraid of the influence of signal intensity reflected by the object
- Equipped with red light/infrared light source, modulated pulse light, strong anti-interference capacity

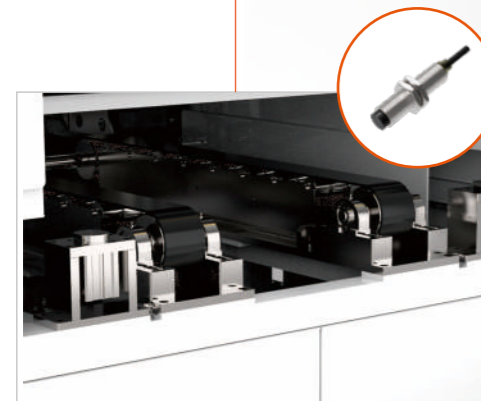

## Trolley positioning

Proximity Sensor  
**TRN Series**

- IP67
- Built-in clear indicator, easy to use

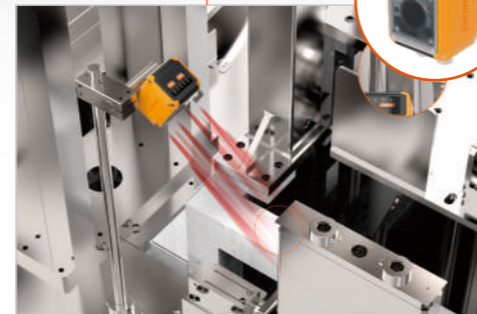

## Battery shell laser carving code reading

Intelligent Code Reader  
**RCD-AI100-X Series**

- Red, white and polarized light sources available
- Support high-density, short-range, medium-range, long-range code reading
- Ultra-high resolution, supporting ultra-small code reading

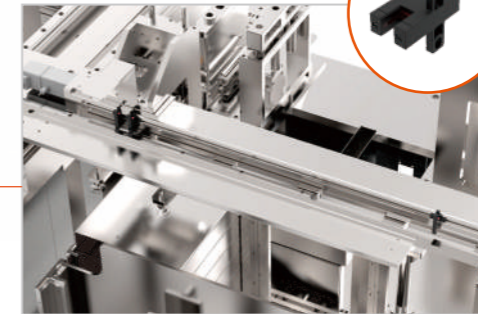

## Mechanism transfer

Slot Sensor  
**ST-303N-W**

- Repeat accuracy up to 0.01mm, supporting L.on/D.on
- 12 shapes for option like F/T/R/L/K/T,etc.



## Battery pack laser engraving QR code reading Area protection around manipulator

### Battery pack laser engraving QR code reading

#### Application:

A QR code, which contains the traceability information that needed to be read and saved is laser engraved on the surface of battery pack. Customer wants the sensor can not only stably recognize DPM code on a highly reflective surface in a fast and effectively (< 50ms) manner, he wants the sensor can detect as many codes as possible for there could be 2 or more codes on the production line at the same time, and to minimize future equipment upgrades.

#### Solution:

AKUSENSE's RCD serie code readers. Thanks to the latest OCR recognition algorithm, RCD series can detect QR codes on different materials and achieve high-speed reading regardless of whether the barcode is damaged or poorly printed. AKUSENSE Code readers offer a full range of industrial communication protocols including Ethernet, Modbus TCP, PROFINET, they can read more than 9 major codes on the market from multi-angle at the same time. The readers also provide users with four groups of independent lights, making light intensity configuration possible, with all these features, RCD scanner easily meet customer's requirements.

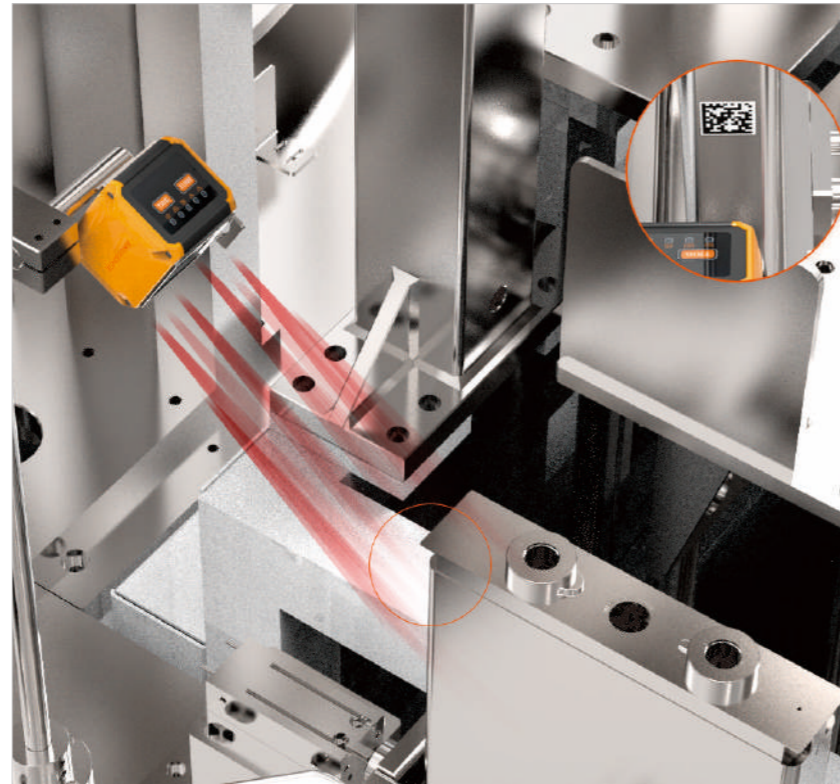

### Piston movement monitoring

#### Application:

The high moving speed of piston inside the cylinder puts forward high standard to the response time and repeatability for the sensor.

#### Solution:

MR series cylinder sensors are used for their 4.5 mT sensitivity and 5 us repeatability. They are directly mounted onto the cylinder and can be fixed to almost any T-slot, C-slot, U-slot, clean-line, tie rod, integrated profile or trapezoidal slot cylinder. AKUSENSE's also offer GF strengthened PBT housing material for demanding application environment.

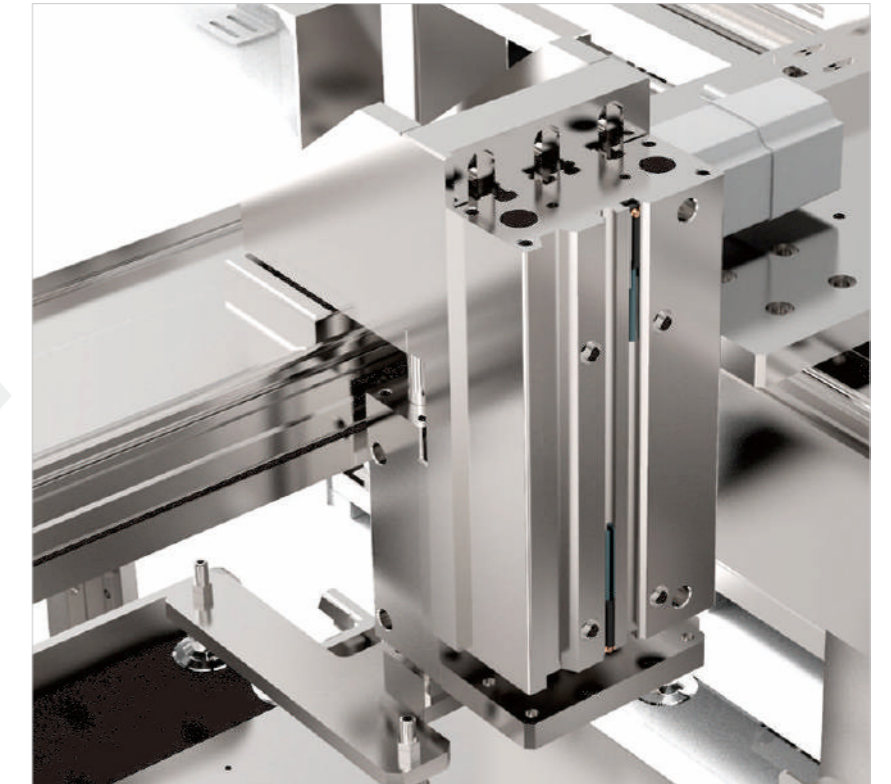

### Area protection around manipulator

#### Application:

There are rapid movements of robotic arms in the loading area, which may pose threat to personal and equipment. The installation space is small, and regular-sized light curtain sensor can't meet the installation requirements.

#### Solution:

We offer ultra slim type light curtain sensor BZL to customer. With a 17.2mm thick aluminum alloy structure, the BZL light curtain not only saves installation space for customers, but also allows the sensor to operate stably even if it is impacted or collided. BZL sensor offers customer with millisecond-level response time, preventing incidence from happening at the very first time.

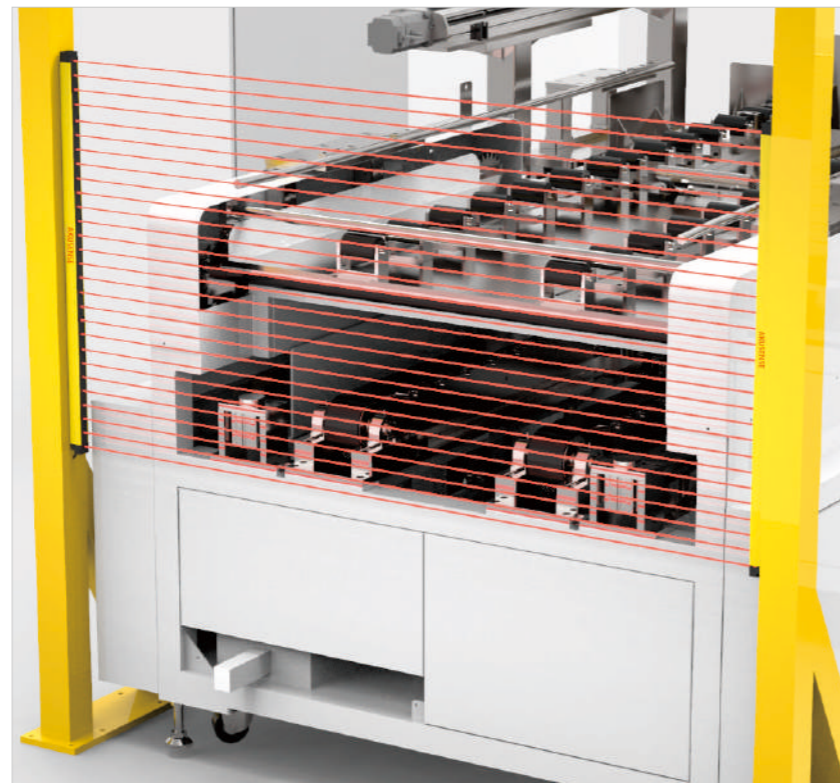



# Laser welding machine

The quality of welding directly and highly affects the quality of Li-ion battery. As a high-precision, flexible and efficient welding method, laser welding can meet the welding requirements and thus become an important process in the battery manufacturing process.

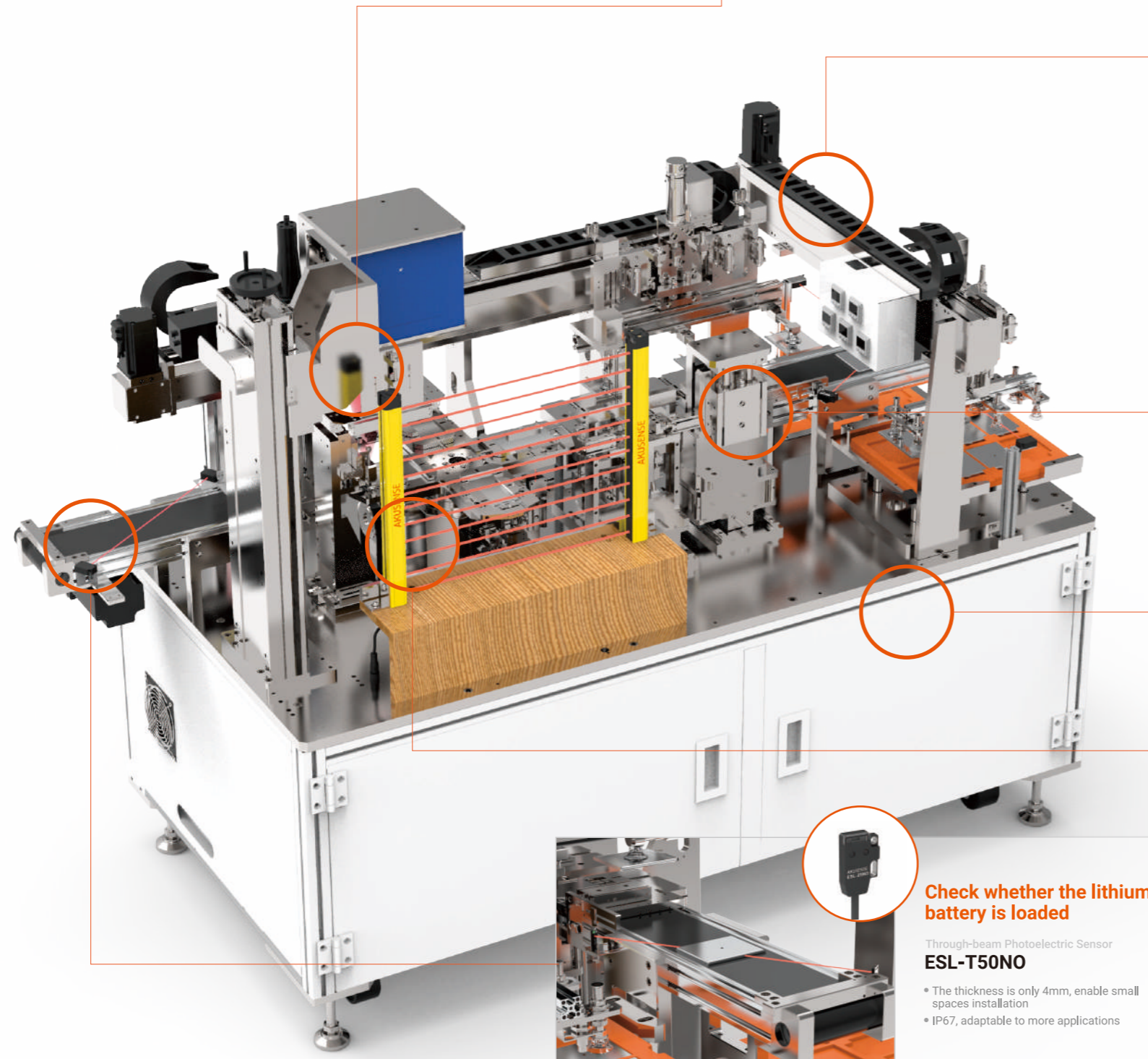

**Defects inspection after the welding process**

AI Image Recognition Technology  
**MEIJI AIV Platform**

- Visualizing training process, realizing consumer-grade product experience
- Test results are clear at a glance, quick delivery



**Motion mechanism positioning**

Slot Sensor  
**ST-303N-W**

- Repeatability high up to 0.01mm, NO/NC switchable
- The slot depth is 8.5mm, effectively prevent damage for happening



**Piston positioning for cylinder**

Magnetic Sensor  
**MR-C8-U-S**

- High positioning accuracy, reliable performance
- 5us ultimate response time



**Temperature monitoring for chiller**

Temperature Sensor  
**TSS Series**

- Suitable for small pipe and confined spaces
- -20~300°C measuring range, fast response time



**Check whether the lithium battery is loaded**

Through-beam Photoelectric Sensor  
**ESL-T50NO**

- The thickness is only 4mm, enable small spaces installation
- IP67, adaptable to more applications



**Equipment safety protection**

Safety Light Curtain  
**BSL Series**

- Support finger, palm, arm detection
- Various appearances, protection heights, and detection methods for option



## Temperature monitoring for chiller Check whether the lithium battery is loaded

### Temperature monitoring for chiller

#### Application:

The temperature of the chiller is monitored in real time to prevent the equipment from over heated, the detection accuracy is required to be 0.1°C, and the detection temperature ranges from 5~+35°C; the available installation space of the equipment is small.

#### Solution:

TSP series temperature sensor. With a thin probe, the sensor is able to measure -30~+150°C for liquids and gases; TSP offers different probes length including 25mm and 100mm for option.

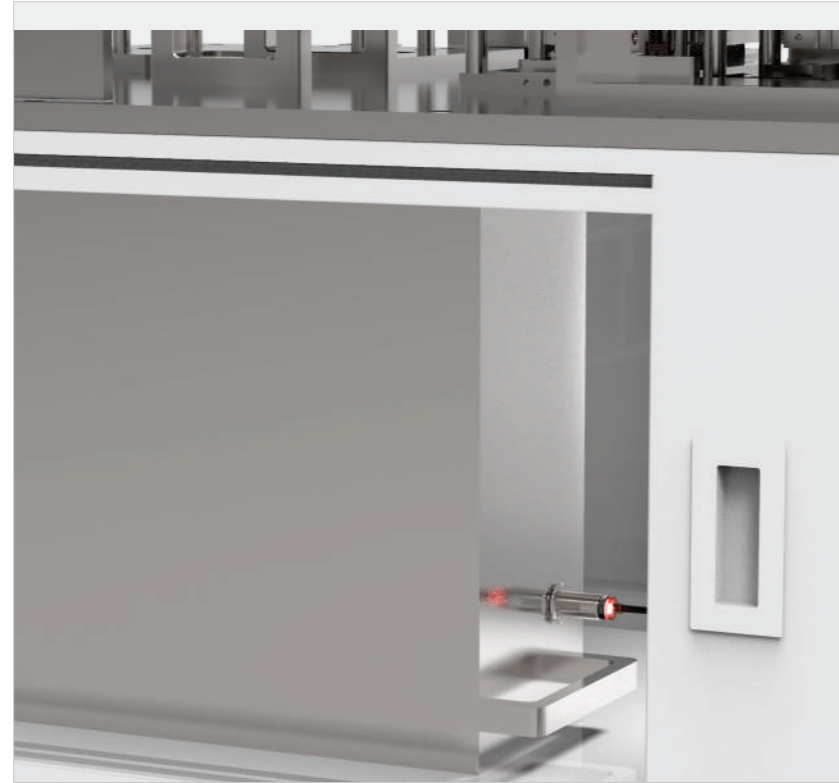

### Check whether the lithium battery is loaded

#### Application:

The installation space is limited, and jitter will occur during the operation of the equipment. Therefore, the customer requires that the sensor should not only be small in size, but also shock resistance. In addition, the color of lithium battery varies, hence detection is required to be unaffected by the color; in order to meet the high volume production requirement, the sensor response time should be less than 2ms.

#### Solution:

Ultra-thin thru-beam photoelectric ESL sensor is offered. Along with good shock performance, the sensor is able to detect li-ion batteries of any shape, color, and material. Coupling with its ultra-thin body and < 1.2 ms response time, it can easily meet customer requirements.

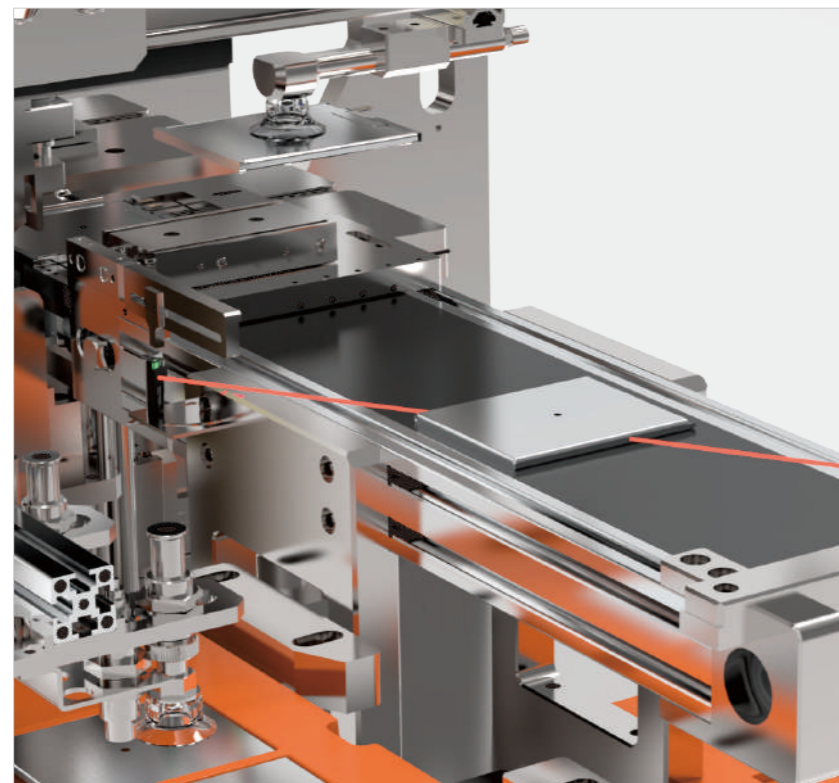

## Defects inspection after the welding process

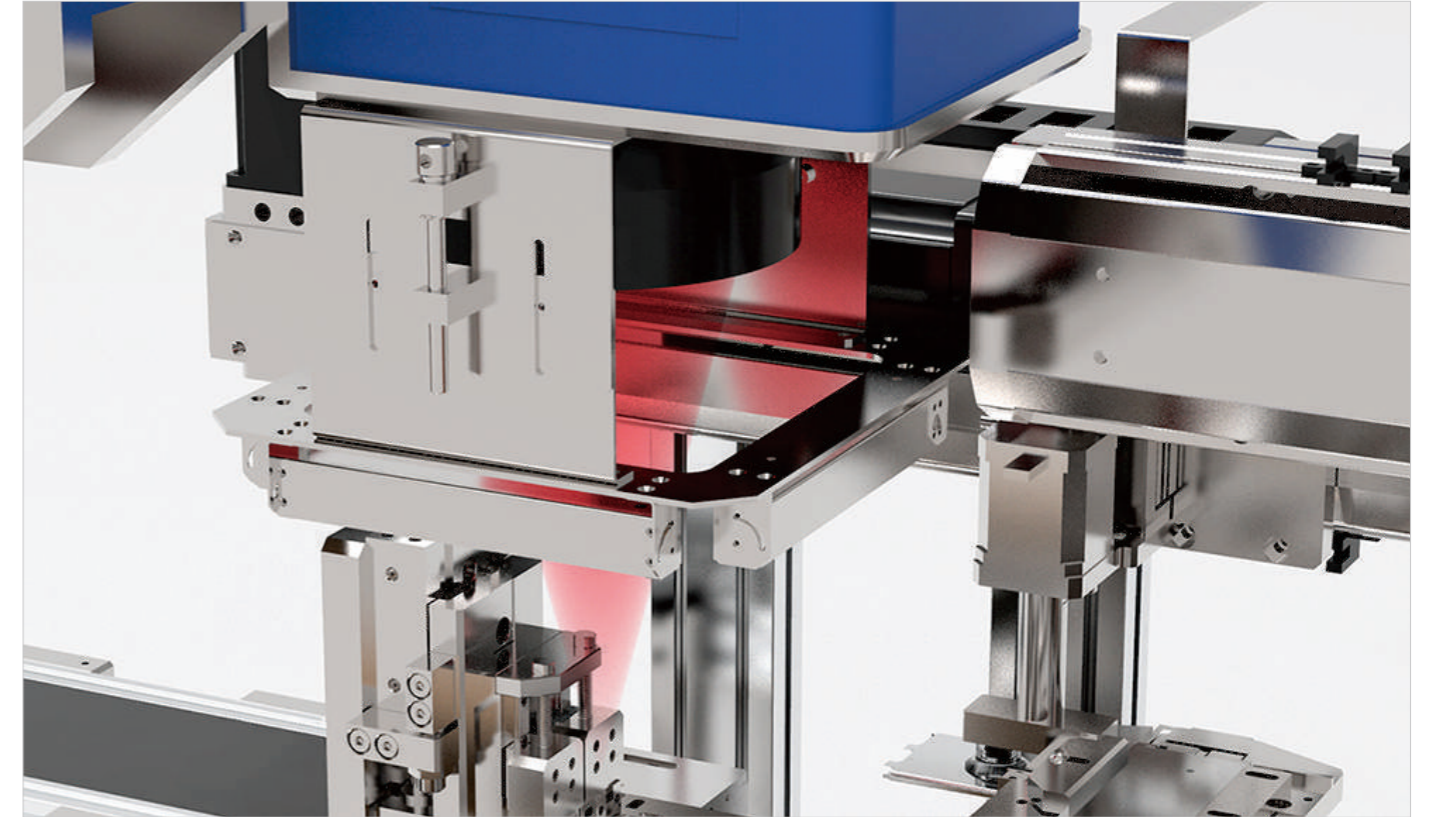

### Defects inspection after the welding process

#### Application:

Common welding issues like cracks, porosity, penetration and fusion, undercut will affect the quality of battery, while the problems are difficult to be identified by traditional vision algorithm.

#### Solution:

The MEIJI AIV platform is used to independently train AI algorithms for complex scenarios such as material tracking, defect location, counting, and multi-category appearance defect detection. AKUSENSE AIV provides extremely fine recognition capabilities. It can learn the marked structure information of the target through self-coding, and identify 4 to 5 pixel densities that cannot be recognized by ordinary algorithms; it also has super model parallel processing capabilities, can perform image processing on multi-card machines, can process 4 times the field of view of a normal network, and can process a single image with up to 100 megapixels, achieving 15+ defect detection with 99%+ accuracy.



# Smart warehousing

In order to build smart factories, improve the condition of raw material storage and transportation, reduce losses caused by misoperation during the sorting process, and improve operational efficiency, smart logistics systems are urgently needed.

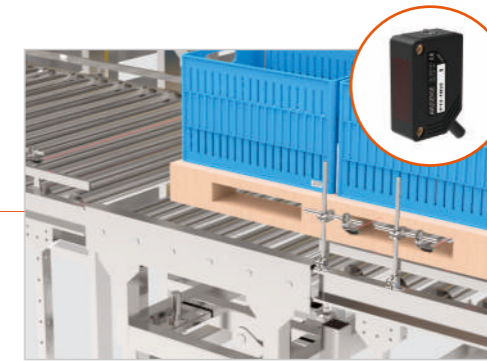

## Position limitation

- Through-beam Photoelectric  
**PTV-TM20AP**
- Anti-interference
  - Large beamwidth, easy to install and adjust

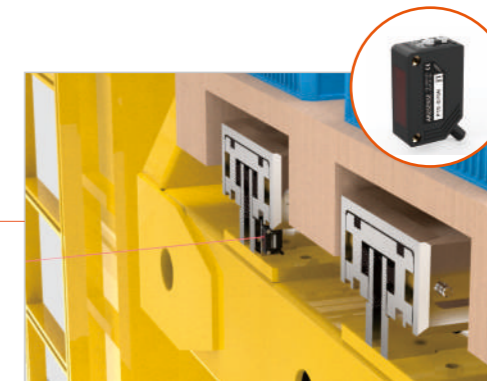

## DPresence/absence detection

- Photoelectric Sensor  
**PTE-D70N**
- Adopts advanced anti-interference algorithm, features with excellent stability
  - Response speed <1ms, 5~1000mm sensing range.



## Obstacle avoidance for stacker

- 2D Lidar  
**AS-31C**
- 270° scanning within 20 meters, angular resolution 0.12°
  - Dirt, light, rain immune.

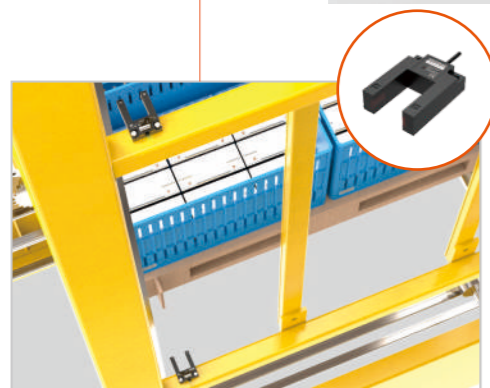

## Shuttle positioning and speed limitation

- Slot Sensor  
**KIM30-0304P-J**
- 30mm slot width, response speed ≤0.6ms, can detect opaque objects above φ2mm
  - Good anti-interference performance and good stability



## AGV obstacle avoidance

- 2D Lidar  
**AS-33C**
- 270° scanning within 10 meters range
  - Equipped with self-diagnosis function and abnormal alarm function

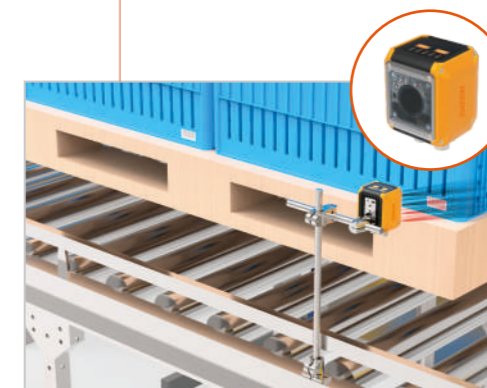

## Production traceability

- Smart Code Reader  
**RCD-AI100-X Series**
- Red, white and polarized light sources available
  - Long reading range
  - Super high resolution, supports ultra-small code reading



## AGV navigation Obstacle avoidance for stacker

### AGV navigation

#### Application:

During the transportation process, the AGV needs to choose its own transportation path. This application requires lidar detection accuracy within centimeters, and the ability to detect multiple targets at the same time, and to set the detection area arbitrarily.

#### Solution:

AKUSENSE obstacle avoidance Lidar AS-31C adopts TOF principle to monitor the distance between the stacker and obstacles, thereby achieving precise obstacle avoidance or positioning. AS-31C offer 270°scanning angle in 20m range for option. With 0.12°angular resolution, 30Hz scanning frequency, 0.05°resolution, and 1cm error, AS-31C can be adapted to various detection scenarios.

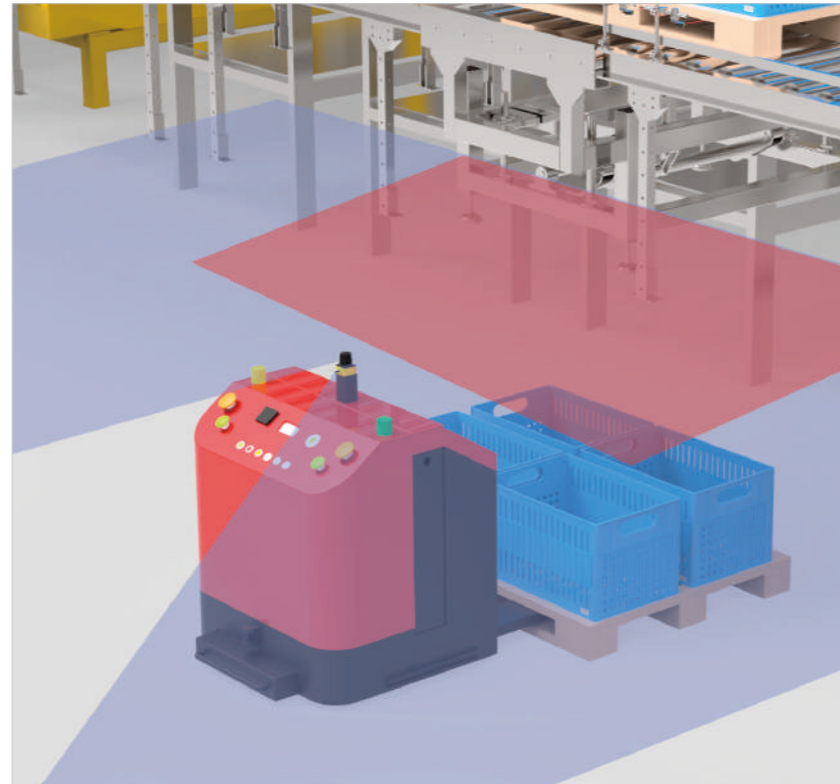

## Production traceability

### Production traceability

#### Application:

From the moment batteries enter the warehouse, manufacturing information needed to be read and stored for subsequent traceability and control.

#### Solution:

The RCD-AI100-X smart code readers offer megapixels and 16 flexible light tuning solutions. It has outstanding code reading performance for highly reflective objects like battery. The RCD-AI100-X series also equipped with deep learning algorithms and networking functions, stable reading can still be achieved even if the barcode is dirty, blurred, scratched, etc.



### Obstacle avoidance for stacker

#### Application:

Electrolyte filled battery needs to be transported and place statically to make the electrolyte to be fully infiltrated. The transportation process needs to pass through a stacker, where Lidar is needed for collision prevent.



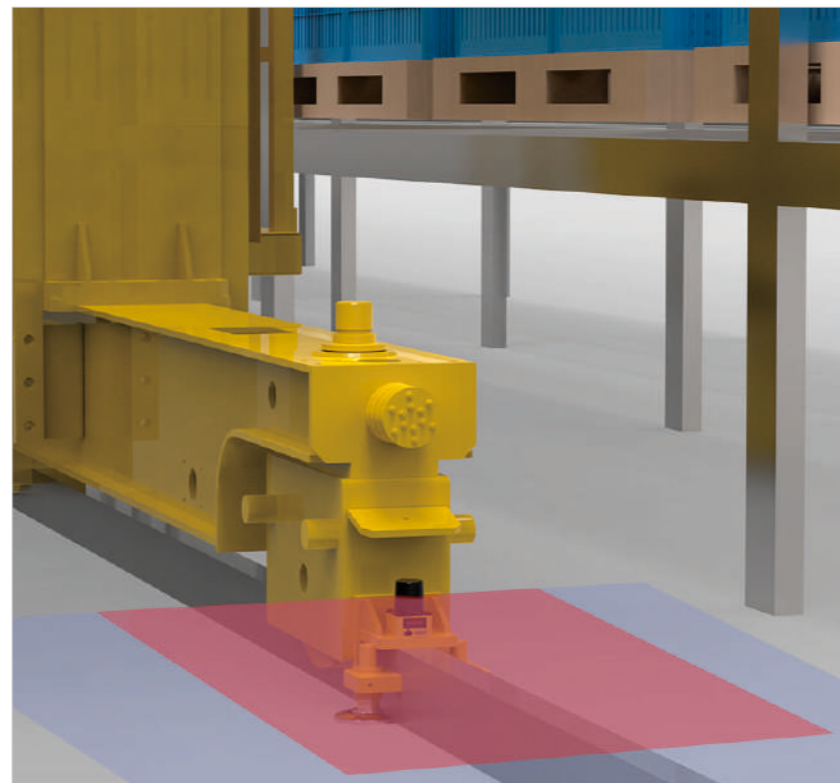

#### Solution:

The stacker is equipped with 2d Lidar AS-33C to prevent collision from happening. AS-33C supports 3 areas monitoring in a single channel (64 channels in total). The software provided by AKUSENSE can display the status information of objects within the measurement range of the detection sensor in real time and give alarm signals (attention, early warning, alarm); AS-33C can perform 270° detection within a 10-meter scanning range, and also has equipment self-testing functions to meet application needs.













## Fiber optic amplifier

Model	PG1-N/P	PE1-N/P	PC1-NH/PH/NH2/PH2	PC3-NPH/NPH2
Image				
Light source	Red,4-elements LED	Red modulated light 630nm	Red LED 660nm	Red LED 660nm
Power	12~24V DC±10%	12~24V DC	12~24V DC	12~30V DC±10%
Switching mode	-	L.on / D.on switchable	L.on / D.on switchable	L.on / D.on switchable
Output mode	NPN or PNP open collector	NPN or PNP open collector	Single/dual channel NPN or single/dual channel PNP	Integrated dual output, NPN / PNP switchable
Response time	SHP: 13µs,FINE: 30µs, SUPR: 100µs,MEGA: 200µs	160us (1-HS)/320us (2-FS)/ 960us (3-ST)/1.92ms (4-LG)/ 3.84ms (5-PL)	16µs/22µs(1-HS), 70µs(2-FS) 250µs(3-ST), 500µs(4-LG) 1ms(5-PL), 2ms(6-UL), 8ms(7-EL)	16µs,70µs,250µs,500µs, 1ms,2ms,8ms
protection degree	-	IP50	IP50	IP54
Application cases	Lithium Winding Machine P12; Lithium Wrapping Machine P20; Lithium Tab Cutting Machine P24			

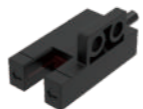
## Fiber Components

Model	PD-32	PD-42	PD-62	PD-C310-35FA
Image				
Detection method	Diffuse reflection	Diffuse reflection	Diffuse reflection	Diffuse reflection
Size	M3	M4	M4	M3
Minimum bending radius	R15	R15	R15	R15
Detection distance	With PC1:120mm With PG1:60mm	With PC1:120mm With PG1:45mm	With PC1:350mm With PG1:150mm	With PC1:220mm With PG1:90mm
Application cases	Lithium Winding Machine P12; Lithium Wrapping Machine P20; Lithium Tab Cutting Machine P24			

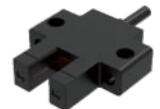
## Slot type





Model	SF-302N/NA/P/PA-W	ST-303N/NA/P/PA-W	SR-304N/NA/P/PA-W	SL-305N/NA/P/PA-W	SK-306N/NA/P/PA-W	SY-307N/NA/P/PA-W
Image						
Detection distance	5mm (slot width)					
Detection of standard objects	Opaque objects over 1.2*1.8mm					
Repeatability	Below 0.03mm					
Output mode	NPN or PNP open collector					
Response frequency	3KHz					
Protection degree	IP50					
Application cases	Lithium Winding Machine P12; Lithium Laminating Machine P16; Lithium Wrapping Machine P20; Lithium Tab Cutting Machine P24; Lithium Shelling Machine P28; Lithium Laser Welding Machine P32					

## Wide slot type



Model	KIM30-0304N/P-J
Image	
Detection method	Thru-beam
Detection distance	30mm
Current consumption	≤15mA
Response time	≤0.6ms
Light source	Infrared 940nm (modulated)
Protection degree	IP65
Application cases	Lithium Smart Storage P36





## PTE Series

Model	PTE-D70N/P	PTE-X09N/P	PTE-R200N/P	PTE-TM10NO/PO	PTE-TM10AN/AP
Image					
Detection method	Diffuse reflection	Convergent reflective	Retro-reflection	Thru-beam	Thru-beam
Detection distance	5~1000mm	5~140mm	2m	10m	10m
Spot size	about $\phi$ 50mm / 1000mm	about $\phi$ 9mm / 140mm	$\phi$ 50mm / 2m	Opaque objects over $\phi$ 12mm	Opaque objects over $\phi$ 12mm
Response time	<1ms	<1ms	<1ms	3.3ms	3.3ms
Light source	Red LED 623nm (modulated)	Red LED 623nm (modulated)	Red LED 623nm (modulated)	Red LED 623nm (modulated)	Red LED 623nm (modulated)
Protection degree	IP65	IP65	IP65	IP65	IP65
Application cases	Lithium Winding Machine P12; Lithium Tab Cutting Machine P24; Lithium Shelling Machine P28; Lithium Smart Storage P36				

## ESL Series

Model	ESL-25NC/NO/PC/PO	ESL-T50NC/NO/PC/PO	ESL-TM01NC/NO/PC/PO
Image			
Detection method	Convergent reflective	Thru-beam	Thru-beam
Detection distance	2~25mm Non-adjustable	500mm non-adjustable	1m Non-adjustable
Detecting object	50*50mm white card	$\phi$ 2mm opaque	$\phi$ 2mm opaque
Response time	$\leq$ 1.2ms	$\leq$ 1.2ms	$\leq$ 1.2ms
Light source	Infrared LED 950nm (modulated)	Infrared LED	Red light
Protection degree	IP67	IP67	IP67
Application cases	Lithium Laminating Machine P16; Lithium Welding Machine P32		

## PTJ Series





Model	PTJ-T80NO/NC/PO/PC-I	PTJ-T150NO/NC/PO/PC-I
Image		
Detection method	Thru-beam	Thru-beam
Detection distance	80cm non-adjustable	150cm non-adjustable
Detection of standard object	Opaque objects over $\phi$ 6mm	Opaque objects over $\phi$ 6mm
Response time	3.3ms	3.3ms
Light source	Infrared LED 850nm (modulated)	Infrared LED 850nm (modulated))
Protection degree	IP64	IP64
Application cases	Lithium Laminating Machine P16	

## ESB Series

Model	ESB-S10N/P	ESB-15N/P	ESB-30N/P	ESB-V30N/P	ESB-C20N/P
Image					
Detection method	Diffuse reflection-BGS	Diffuse reflection-BGS	Diffuse reflection-BGS	Diffuse reflection-BGS	Diffuse reflection-BGS
Detection distance	5~100mm	5~150mm	0 to 300mm (White non-glossy paper)	10~300mm	10~200mm
Spot size	About $\phi$ 1.5mm/10cm	About $\phi$ 9mm/15cm	About $\phi$ 16mm/30cm	-	About $\phi$ 12mm/200mm
Response time	$\leq$ 2ms	5ms	$\leq$ 2ms	<1ms	$\leq$ 2ms
Light source	Red LED small spot 623nm (modulated)	Red LED small spot 623nm (modulated)	Red LED small spot 623nm (modulated)	Red LED small spot 940nm (modulated)	Red LED small spot 623nm (modulated)
Protection degree	IP65	IP65	IP65	IP65	IP65
Application cases	Lithium Wrapping Machine P20; Lithium Shelling Machine P28				



## PTV Series

Model	PTV-D30N/P	PTV-D70N/P	PTV-X09N/P	PTV-TM20NO/PO/NO/PO	PTV-T500N/P
Image					
Detection method	Diffuse reflection	Diffuse reflection	Convergent reflective	Thru-beam	Thru-beam
Detection distance	10-300mm	5-1000mm	5-140mm	20m Non-adjustable	5m
Light source	Infrared LED (940nm modulation)	Infrared LED (940nm modulation)	Infrared LED (940nm modulation)	Infrared LED (940nm modulation)	Infrared LED (940nm modulation)
Response time	<1ms	<1ms	<1ms	<5ms	<5ms
Load current	<100mA	<100mA	<100mA	<100mA	<100mA
Protection degree	IP65	IP65	IP65	IP65	IP65
Application cases	Lithium Smart Storage P36				



## ELE Series

Model	ELE-B15N/P	ELE-D40N/P	ELE-RM05N/P	ELE-TM30N/P
Image				
Detection method	Diffuse reflection-BGS	Diffuse reflection	Retro-reflection	Thru-beam
Detection distance	1~15mm	40cm	5m	30m
Spot size	about $\phi$ 1.5mm/15cm	about $\phi$ 1.5mm/40cm	about $\phi$ 20mm/5m	about $\phi$ 60mm/30m
Response time	$\leq$ 2ms	$\leq$ 2ms	$\leq$ 2ms	$\leq$ 2ms
Return range	$\leq$ 5%SN	$\leq$ 20%SN	$\leq$ 20%SN	$\leq$ 20%SN
Protection degree	IP65	IP65	IP65	IP65
Application cases	Lithium Tab Cutting Machine P24			

## ESC/ESE Series

Model	ESC-18N/P	ESE-10N/P
Image		
Detection method	Diffuse reflection	Diffuse reflection
Detection distance	18 $\pm$ 2mm	10mm $\pm$ 3mm
Spot size	$\phi$ 6mm/18mm	1x5mm(setting distance:10mm)
Response time	Mark mode:H1/0.25ms,H2/0.5ms,L/1.2ms Color mode:H1/0.8ms,H2/1.6ms,L/4ms	Mark mode:0.5ms; Color mode:2ms
Light source	RGB three-colour light source	Red/blue/green composite LED (peak throw wavelength: 625nm/470nm/525nm)
Protection degree	IP67	IP67
Application cases	Lithium Coating Machine P08	

## TRN Series



Model	TRN6.5-02NO	TRN08-02NO	TRN12-04NO	TRN18-08NO	TRN30-15NO
Image					
Mounting	Unshielded	Unshielded	Unshielded	Unshielded	Unshielded
Detection distance	2mm $\pm$ 10%	2mm $\pm$ 10%	4mm $\pm$ 10%	8mm $\pm$ 10%	15mm $\pm$ 10%
Size	$\phi$ 6.5	M8	M12	M18	M30
Switching frequency	2KHz	1KHz	800Hz	500Hz	150Hz
Repeatability	< 1.0%(Sr)	< 1.0%(Sr)	< 5.0%(Sr)	< 1.0%(Sr)	< 1.0%(Sr)
Protection degree	IP67	IP67	IP67	IP67	IP67
Application cases	Lithium Coating Machine P08; Lithium Tab Cutting Machine P24;Lithium Shelling Machine P28				



## TQ Series

Model	TQF17-05NO	TQF18-05NO	TQF18C-05NO
Image			
Mounting	Shielded	Shielded	Shielded
Detection distance	5mm±10%	5mm±10%	5mm±10%
Size	Q17	Q18	Q18C
Switching frequency	1KHz	1KHz	1KHz
Repeatability	< 1.0%(Sr)	< 1.0%(Sr)	< 1.0%(Sr)
Protection degree	IP67	IP67	IP67
Application cases	Lithium Laminating Machine P16		

## MLD Series

Model	MLD21-100/220/500A-485	MLD23-30/100/200N
Image		
Reference distance	100/220/500mm	30/100/200mm
Detection distance	65~700mm	25~280mm
Linear accuracy	±0.1% / ±0.2% / ±0.3%	±0.1% / ±0.2%F.S.
Repeatability	70µm/200µm/300µm/600µm	10µm/70µm/200µm
Light source	Laser CLASS 2	Red Semiconductor Laser Wavelength: 655nm 1mW Class2
Protection degree	IP67	IP66
Application cases	Lithium Coating Machine P08; Lithium Laminating Machine P16	

## ETD Series

Model	ETD-0612
Image	
Detection method	Thru-beam
Measurement range	Edge mode: ±6mm; Width mode: 12mm
Spot size	-
Linear accuracy	±0.12% F.S. (when setting distance 20mm); ±0.28% F.S. (when setting distance 100mm)
Repeatability	1µm (at a setting distance of 20mm); 2.5µm (at a setting distance of 100mm); 5µm(at the setting distance of 500mm)
Protection degree	IP50
Application cases	Lithium Coating Machine P08; Lithium Winding Machine P12

## AS Series

Model	AS-31C	AS-32C	AS-33C
Image			
Laser spot	7*3mm	4.5*2mm	-
Scanning angle range	270°	270°	270°
Scanning frequency	10Hz/15Hz/20Hz/25Hz/30Hz	10Hz/15Hz/20Hz/25Hz/30Hz	25Hz
Scanning angle resolution	0.12°/0.18°/0.23°/0.35°	0.12°/0.18°/0.23°/0.35°	0.5°
Detection distance	0.1m~20m (70% reflectivity)	0.1m~20m (70% reflectivity)	10m (70% reflectivity) 4m (10% reflectivity)
Data sampling rate	30KHz	30KHz	18KHz/54KHz
Application cases	Lithium Smart Storage P36		



## MR Series

Model	MR-C7-S/N	MR-C8-C/U-S/N
Image		
Applicable slot type	C type	C+U type
Detecting magnetic poles	N-pole and S-pole models available	N-pole and S-pole models available
Magnetic sensitivity	4.5~6mT	4.5~6mT
Response time	5ms	5ms
Output method	NPN Normally Open (N.O.) (ON for proximity)	NPN Normally Open (N.O.) (ON for proximity)
Protection degree	IP67	IP67
Application cases	Lithium Winding Machine P12; Lithium Wrapping Machine P20; Lithium Tab Cutting Machine P24; Lithium Shelling Machine P28; Lithium Laser Welding Machine P32	



## MUD Series

Model	MUD-60N/P-18-GL
Image	
Detection distance	30~60mm
Blind spot	5mm in front of the transmitter and receiver
Angle deviation	±45° from vertical
Transducer frequency	400kHz / 200kHz
Response time	2.5ms in autorun mode / 6.5ms in autorun mode
Protection degree	IP65
Application cases	Lithium Laminating Machine P16

## BSL/BZL/SAF Series

Model	BSL Series	BZL Series	SAF Series
Image			
No. of optical axes	4~32 axes	6~32 axes	4~72 axes
Protection height	90~1240mm	50~1240mm	130~3000mm
Protection distance	123.1~1273.1mm	0.3~3m	0.1~40m
Optical axis spacing	30/40mm	10/14/20/25/30/40mm	10/20/30/40mm
Response time	≤20ms	≤15ms	≤20ms
Protection degree	IP65	IP65	IP65
Application cases	Lithium Coating Machine P08; Lithium Winding Machine P12; Lithium Shelling Machine P28; Lithium Laser Welding Machine P32		

## TSP Series

Model	TSS-20300A/V1/V2	TSS-100A/V1/V2
Image		
Measurement range	-20°C ~ 300°C	0°C ~ 100°C
Temperature Accuracy	± 2% of the measured value	± 2% of the measured value
Repeat Accuracy	± 1% of the measured value	± 1% of the measured value
Resolution	1°C	1°C
protection degree	IP65	IP65
Dimension	67*18mm, M18 thread	67*18mm, M18 thread
Application cases	Lithium laser welding machine P32	





# Sensor Parameter

## VDS10 Series

Model	VDS10 Series
Image	
Resolution	1280×800(HxV)
Maximum capture frame rate	60
Shutter	Global shutter
Pixel Size (μm)	3×3
Target Size	1/4"
Light source	Unpolarised red light/unpolarised white light/polarised red light/polarised white light
Application cases	Lithium Coating Machine P08; Lithium Tab Cutting Machine P24; Lithium Shelling Machine P28;

## RCD-AI100 Series

Model	RCD-AI100-X Series	RCD-AI100-S Series
Image		
Resolution	1280×800	1280×800
Read Maximum Speed	60pcs/second	60pcs/second
Pixel size	3 um x 3 um	3 um x 3 um
Focusing Method	Mechanical Focus	Liquid Focus / Manual Focus
Light source	Unpolarised red light, unpolarised white light, polarised red light, polarised white light	Unpolarised red light, unpolarised white light, polarised red light, polarised white light
Identifiable coding	one-dimensional code: Code 39, Code93, Code128, EAN-8, EAN-13, Interleaved 2 of 5, UPC; two-dimensional barcode: QR code, DataMatrix	one-dimensional code: Code 39, Code93, Code128, EAN-8, EAN-13, Interleaved 2 of 5, UPC; two-dimensional barcode: QR code, DataMatrix
Application cases	Lithium Shelling Machine P28; Lithium Shelling Machine P36	